

Eox™ 30W

PRODUCT REFERENCE GUIDE



CO2 Laser Marker

Datalogic S.r.l.

Via S. Vitalino, 13
40012 Calderara di Reno (BO)
Italy
Tel. +39 051 3147011
Fax +39 051 3147205

© 2021-2022 Datalogic S.p.A. and /or its affiliates

All rights reserved. Without limiting the rights under copyright, no part of this documentation may be reproduced, stored in or introduced into a retrieval system, or transmitted in any form or by any means, or for any purpose, without the express written permission of Datalogic S.p.A. and/or its affiliates.

Owners of Datalogic products are hereby granted a non-exclusive, revocable license to reproduce and transmit this documentation for the purchaser's own internal business purposes. Purchaser shall not remove or alter any proprietary notices, including copyright notices, contained in this documentation and shall ensure that all notices appear on any reproductions of the documentation.

Electronic versions of this document may be downloaded from the Datalogic website (www.datalogic.com). If you visit our website and would like to make comments or suggestions about this or other Datalogic publications, please let us know via the "Contact" page.

Disclaimer

Datalogic has taken reasonable measures to provide information in this manual that is complete and accurate, however, Datalogic shall not be liable for technical or editorial errors or omissions contained herein, nor for incidental or consequential damages resulting from the use of this material. Datalogic reserves the right to change any specification at any time without prior notice.

Trademarks

Datalogic and the Datalogic logo are registered trademarks of Datalogic S.p.A. in many countries, including the U.S.A. and the E.U.

Eox and Lighter Suite are trademarks of Datalogic S.p.A. and/or its affiliates. All other trademarks and brands are property of their respective owners.

This manual refers only to Eox™ 30W models running Windows 10 operating system (6302-1X41).

ORIGINAL INSTRUCTIONS (ref. 2006/42/EC).

TABLE OF CONTENTS

PREFACE	VI
About this Manual	vi
Manual Conventions	vi
Technical Support	vi
Support Through the Website	vi
Warranty	vii
CHAPTER 1. INTRODUCTION	1
General	1
Model Description	2
Compliance	3
European Declaration of Conformity	3
UKCA Declaration of Conformity	3
FCC Compliance	3
EAC Compliance	3
Laser Standards	4
Overview	5
Operation of a Laser Marker with Galvometric Scanning	5
Laser Source	5
Galvanometric Scanning Head	5
Marking Software	6
Important Warnings	7
CHAPTER 2. INSTALLATION	8
Unpacking	8
Contents of the packaging	10
On moisture condensation	11
Note on moisture condensation	11
If moisture condensation occurs	11
How to avoid moisture condensation	11
Fixing and positioning	12
Control Rack	13
Resonator	14
Mounting screws length	14
Installation environment	15
Control Rack	16
Resonator	17
Fume / Dust extractor	17
CHAPTER 3. TECHNICAL SPECIFICATIONS	18
Technical Characteristics	18
Product Description	20
Control Rack	20
Resonator	21
Marking Area Specification	22
F-Theta Scan Lens	23
Connectors Specifications	24
Interlock	24

Control rack back panel connector	24
Muting Device	25
X1 - Command Box (Laser Control)	26
Control rack back panel connector	26
Muting Device	27
X2 - Axes (I/O Control)	28
Control rack back panel connector	28
Encoder	29
Control rack back panel connector	29
Photocell	29
Control rack back panel connector	29
RS232	30
Control rack back panel connector	30
Input/Output specifications	31
Digital Input	31
Digital Output	31
Laser Marker States	32
Normal Operation States	32
Error States	33
Warning State	33
Control the Laser Marker States	34
Timing Diagrams	35
Turning On sequence	35
Marking control signals behavior	36
Axes I/O signals behavior	37
Lighter™ Suite marking software	38
CHAPTER 4. SET UP	40
Connections	40
Control Rack - Resonator connection	40
Connecting X1 - Command Box connector	45
Connecting Interlock connector	46
Connecting Power Supply cable	47
Local Mode Control connections	48
Remote Mode Control connection	50
F-Theta scan lens protection cap removal	50
CHAPTER 5. USE AND OPERATION	51
Turning On sequence	52
CHAPTER 6. CUSTOMIZE THE LASER MARKER SOFTWARE.....	56
System Protection	56
System Protection Tool	56
How to use the System Protection tool	57
Change O.S. language and keyboard layout	60
Change the LAN configuration and IP address	63
Change the video setting	66
Remote desktop connection	68
CHAPTER 7. ACCESSORIES	69
Control Box	69
Remote Start Foot Switch	70
I/O interface	70
DB25-to-Free Leads Cable	71
Fume Extractor	71
CHAPTER 8. TECHNICAL SUPPORT	72
Seals	72
Maintenance	73
F-Theta scan lens cleaning procedure	73

Troubleshooting	74
List of warning and error states	74
List of problems related to laser marker states	75
List of most common problems	75
Remote Assistance	77
APPENDIX A. LABELS	79
Labels	79
Positioning of external labels	80
APPENDIX B. LASER SAFETY	81
Laser radiation	82
Absorption of laser radiation	83
Classification and danger level	84
Degree of risk with radiation viewing conditions	84
Direct viewing of the laser beam	84
Viewing of a laser reflected beam	85
Viewing of scattered laser beam	85
N.O.H.D. determination and O.D. of protection goggles	86
EN207 and EN208	87
Eyes and skin risks	88
General safety regulations	88
Other risks	89
APPENDIX C. USING MARKING SOFTWARE	90
How to create and edit graphics layout	90
How to test and mark layout	93
How to use Command Box signals to mark layout	95
APPENDIX D. MARKING SOFTWARE UPGRADE	97
How to update the marking software	97
APPENDIX E. RECOVER THE LASER MARKER	103
Overview	103
How to recover the laser marker	103
Preliminary Operation	104
Recover the system	105
APPENDIX F. MECHANICAL DRAWINGS	113
Control rack	114
ReSONATOR	115

PREFACE

ABOUT THIS MANUAL

This User Manual (UM) is provided for users seeking advanced technical information, including connection, programming, maintenance and specifications. The Quick Reference Guide (QRG) and other publications associated with this product can be downloaded free of charge from the website listed on the back cover of this manual.

Manual Conventions

The symbols listed below are used in this manual to notify the reader of key issues or procedures that must be observed when using the laser marker:



NOTE: Notes contain information necessary for properly diagnosing, repairing and operating the laser marker.



CAUTION: This symbol advises you of actions that could damage equipment or property.



WARNING: This symbol advises you of actions that could result in harm or injury to the person performing the task.

TECHNICAL SUPPORT

Support Through the Website

Datalogic provides several services as well as technical support through its website. Log on to (www.datalogic.com).

For quick access, from the home page click on the search icon , and type in the name of the product you're looking for. This allows you access to download Data Sheets, Manuals, Software & Utilities, and Drawings.

Hover over the Support & Service menu for access to Services and Technical Support.

WARRANTY

Datalogic warrants that the Products shall be free from defects in materials and workmanship under normal and proper use during the Warranty Period. Products are sold on the basis of specifications applicable at the time of manufacture and Datalogic has no obligation to modify or update Products once sold. The Warranty Period shall be **two years** from the date of shipment by Datalogic, unless otherwise agreed in an applicable writing by Datalogic.

Datalogic will not be liable under the warranty if the Product has been exposed or subjected to any: (1) maintenance, repair, installation, handling, packaging, transportation, storage, operation or use that is improper or otherwise not in compliance with Datalogic's instruction; (2) Product alteration, modification or repair by anyone other than Datalogic or those specifically authorized by Datalogic; (3) accident, contamination, foreign object damage, abuse, neglect or negligence after shipment to Buyer; (4) damage caused by failure of a Datalogic-supplied product not under warranty or by any hardware or software not supplied by Datalogic; (5) any device on which the warranty void seal has been altered, tampered with, or is missing; (6) any defect or damage caused by natural or man-made disaster such as but not limited to fire, water damage, floods, other natural disasters, vandalism or abusive events that would cause internal and external component damage or destruction of the whole unit, consumable items; (7) use of counterfeit or replacement parts that are neither manufactured nor approved by Datalogic for use in Datalogic-manufactured Products; (8) any damage or malfunctioning caused by non-restoring action as for example firmware or software upgrades, software or hardware reconfigurations etc.; (9) loss of data; (10) any consumable or equivalent (e.g. cables, power supply, batteries, etc.); or (11) any device on which the serial number is missing or not recognizable.

THE DATALOGIC WARRANTIES ARE EXCLUSIVE AND IN LIEU OF ALL OTHER WARRANTIES, WHETHER WRITTEN, EXPRESS, IMPLIED, STATUTORY OR OTHERWISE, INCLUDING, BUT NOT LIMITED TO, THE IMPLIED WARRANTIES OF MERCHANTABILITY AND FITNESS FOR PARTICULAR PURPOSE. DATALOGIC SHALL NOT BE LIABLE FOR ANY DAMAGES SUSTAINED BY BUYER ARISING FROM DELAYS IN THE REPLACEMENT OR REPAIR OF PRODUCTS UNDER THE ABOVE. THE REMEDY SET FORTH IN THE WARRANTY STATEMENT IS THE BUYER'S SOLE AND EXCLUSIVE REMEDY FOR WARRANTY CLAIMS. NO EXTENSION OF THIS WARRANTY WILL BE BINDING UPON DATALOGIC UNLESS SET FORTH IN WRITING AND SIGNED BY DATALOGIC'S AUTHORIZED REPRESENTATIVE. DATALOGIC'S LIABILITY FOR DAMAGES ON ACCOUNT OF A CLAIMED DEFECT IN ANY PRODUCT DELIVERED BY DATALOGIC SHALL IN NO EVENT EXCEED THE PURCHASE PRICE OF THE PRODUCT ON WHICH THE CLAIM IS BASED. DATALOGIC SHALL NOT BE LIABLE FOR DAMAGES RELATING TO ANY INSTRUMENT, EQUIPMENT, OR APPARATUS WITH WHICH THE PRODUCT SOLD UNDER THIS AGREEMENT IS USED. Further details on warranty coverage, rights and conditions are addressed under and regulated by the Terms and Conditions of Sales of Datalogic available at https://www.datalogic.com/terms_conditions_sales.

CHAPTER 1

INTRODUCTION

GENERAL

Information included in this manual is intended for a qualified installer able to integrate the laser marker into a system, complying with all the protection features required by international rules and local legislations. Refer to the following sections for further information.

This manual refers to Eox™ 30W laser markers, that is a Class 4 Laser Product.

In addition to being professionally trained in their role, personnel assigned to work with laser marker must be informed and made acquainted with the risks inherent to invisible and visible laser radiation. The operator is required to carefully read the section of the manual concerning safety instructions as well as the sections related to matters falling under her/his responsibility.



CAUTION: Datalogic shall not be held responsible for any non-conforming use of the laser marker of its manufacture.



NOTE: BEFORE INSTALLING AND USING THE LASER MARKER, CAREFULLY READ THIS MANUAL.

MODEL DESCRIPTION

Eox™ laser markers are described by their model number which indicates the characteristics listed in the diagram below. Not all combinations are available. For a complete list of combinations see the Models tab on the Product page of the website.

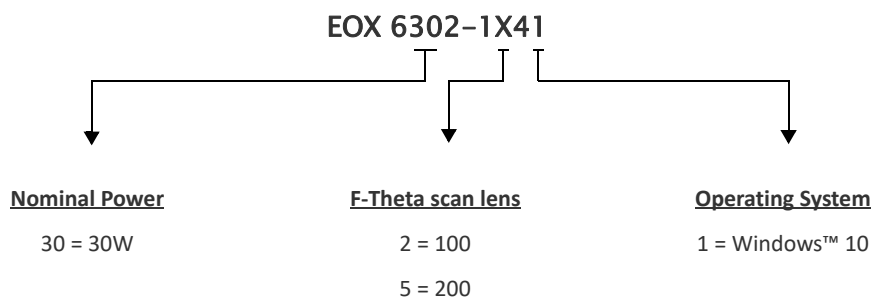

COMPLIANCE

European Declaration of Conformity

Hereby, Datalogic S.r.l. declares that the full text of the European Declaration of Conformity is available at: www.datalogic.com. Select the link from the downloads section of the product page.

UKCA Declaration of Conformity

Hereby, Datalogic S.r.l. declares that the full text of the UKCA Declaration of Conformity is available at: www.datalogic.com. Select the link from the downloads section of the product page.

FCC Compliance

Modifications or changes to this equipment without the expressed written approval of Datalogic could void the permission to use the equipment.

This laser marker complies with PART 15 of the FCC Rules. Operation is subject to the following two conditions: (1) this laser marker may not cause harmful interference, and (2) this laser marker must accept any interference received, including interference which may cause undesired operation.

This laser marker has been tested and found to comply with the limits for a Class A digital device, pursuant to part 15 of the FCC Rules. These limits are designed to provide reasonable protection against harmful interference when the equipment is operated in a commercial environment. This laser marker generates, uses, and can radiate radio frequency energy and, if not installed and used in accordance with the instruction manual, may cause harmful interference to radio communications. Operation of this laser marker in a residential area is likely to cause harmful interference in which case the user will be required to correct the interference at his/her own expense.

EAC Compliance

Customs Union: this laser marker complies with CU Conformity certification; this allows the Product to bear the Eurasian Mark of conformity.

LASER STANDARDS

This laser marker is classified as Class 4 Laser Product according to the following:

EU: EN60825-1

USA: 21 CFR 1040.10

China: GB7247-1

Datalogic, as manufacturer of laser products, provides a laser marker which is NOT intended for immediate use, but it must be connected, by others, to other devices which have the final aim of creating a laser processing system.

The final system manufacturer MUST ensure the safety of the laser processing machine according to its standards including the risk-analysis, implementation of safety measures, certification and testing of safety measures and the production of adequate information for use of the machine.

Datalogic is available for providing to the customers all the information in its possession to help in complying with applicable standards.



WARNING: Use of controls or adjustments or performance of procedures other than those specified herein may result in hazardous radiation exposure.

OVERVIEW

The CO2 laser marker developed and manufactured by Datalogic employs the most advanced technologies with regards to the mechanical-optical part, the electronic control of laser beam power, communication and the overall safety of the entire laser marker.

The laser marker is composed by a single device (All-In-One) with laser head and compact dimensions for an easy integration inside a complex system able to manage marking signals and customer's complementary modules.

All laser marker connections are found on the back of device: supply input, controls and signals and interfaces for internal embedded controller. Moreover is available an inlet air to use to maintain clean the marking area thanks to holes around the focal lens.

Two side cooling fans are provided for cooling down the laser marker; their flow must never be obstructed.

Operation of a Laser Marker with Galvometric Scanning

In pulsed or continuous operation mode, the CO2 generates an invisible, high-energy infrared beam.

In order to obtain a more accurate focus, the laser beam is first enlarged by using an optical expansion system and then deflected by a scanning system consisting of two mirrors mounted on galvanometric motors.

These mirrors deflect the beam in a controlled fashion along the X and Y axes; processing of the product surface occurs by coordinating the movement of the two motors with the turning on/off of the laser beam.

The deflected laser beam is focused by an F-Theta scan lens before it hits the surface of the product.

Generally speaking, the marking is carried out within the focus of the beam.

Laser Source

A sealed gas laser tube is used in the laser marker.

The tube contains a gas mixture (usually CO₂, N₂ and He) which is excited by a radiofrequency generator to bring it to a plasma state.

The produced radiations are reflected back and forth between the mirrors, which represent the "resonant laser cavity"; the laser beam is amplified with each reflection.

While one of the two mirrors (rear) is 100% reflecting, the output mirror (front) reflects only 95%; this slight loss of 5% represents the laser radiation used for etching purposes.

Galvanometric Scanning Head

The scanning head features two deflection mirrors that deflect the beam in an X and Y direction, depending on the graphics/pattern to be reproduced.

Marking Software

The Lighter™ marking software is pre-installed on the product.



NOTE: Consult Lighter™ software user's manual for a proper use of the same.



NOTE: If necessary, see "Marking Software Upgrade" on page 97, to upgrade the pre-installed software.

IMPORTANT WARNINGS

Access to the internal parts of the laser marker is allowed only to authorized personnel, duly qualified and trained with regards to risks of optical and electrical nature.

Datalogic declines any and all responsibility for work carried out on active parts by untrained or unauthorized personnel.



CAUTION: It is forbidden to change the intended use for which the product was designed and developed.

Datalogic declines any and all responsibility for improper use of its laser product.



CAUTION: The integration and use of this laser marker is customer responsibility.



CAUTION: Never expose reflecting surfaces to laser radiation!

The reflected laser beam may cause damage to laser marker.



CAUTION: Laser marking interacts with materials through, for example, a thermal carbonization process which may lead to the emission of fumes, dust and vapors.

Adequate fume/dust extractor and treatment must be provided by customer!



WARNING: Marking PVC (or other plastic material) can cause the release of chlorine gas which can be harmful to the laser operator and to the laser marker itself. Always use adequate fume extractor during PVC and plastic marking.



CAUTION: It is the responsibility of the customer to install the laser marker in proper safety condition!

CHAPTER 2

INSTALLATION

UNPACKING



CAUTION: The Eox™ laser marker is a delicate optical device, that can be damaged by shock and vibrations.

Before installing or operating the laser marker, you should:

- Inspect the shipping container for damage
- Inspect the laser marker for signs of damage
- Confirm that the shipping box contains all items on the shipping inventory list including any accessories

When unpacking the laser marker from the shipping box you should:

- Remove the accessories and documentations
- Carefully remove the laser marker from the packaging using both hands

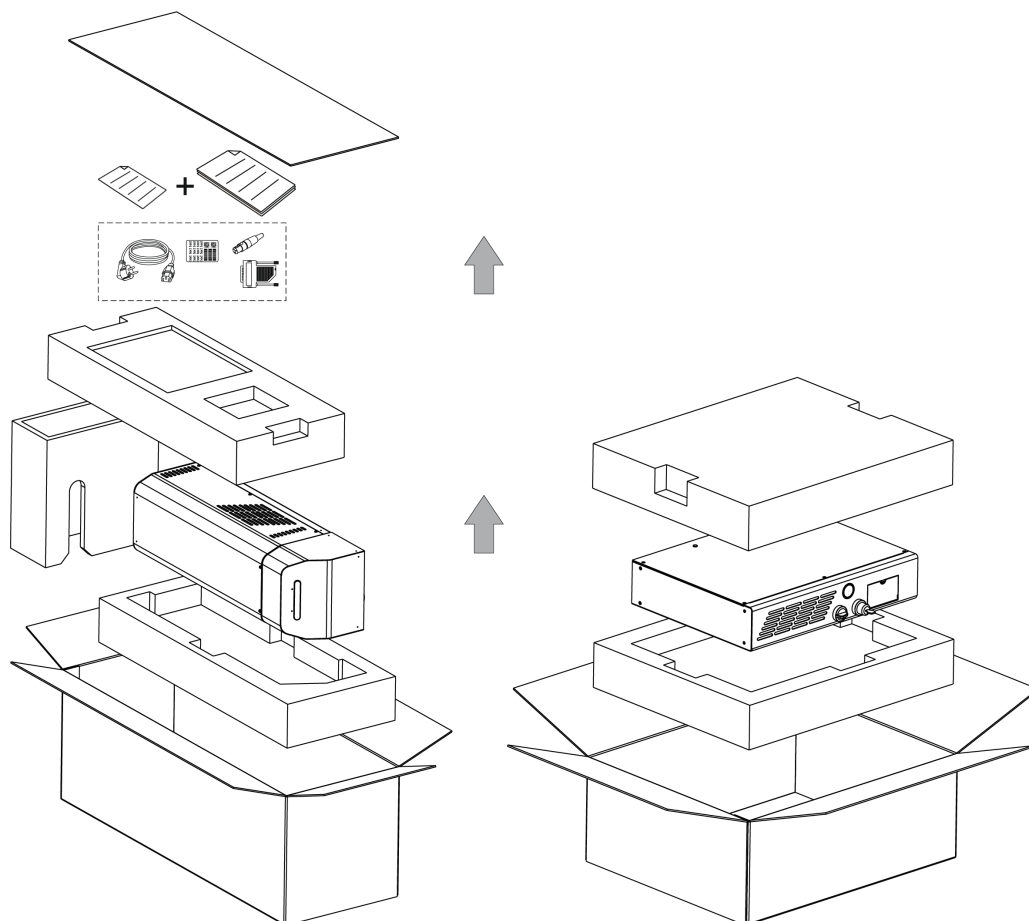
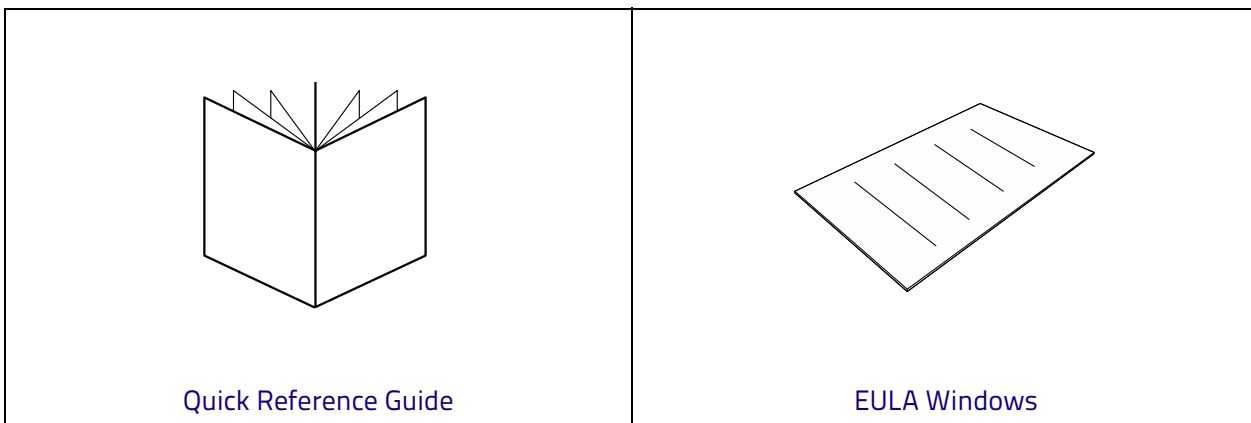
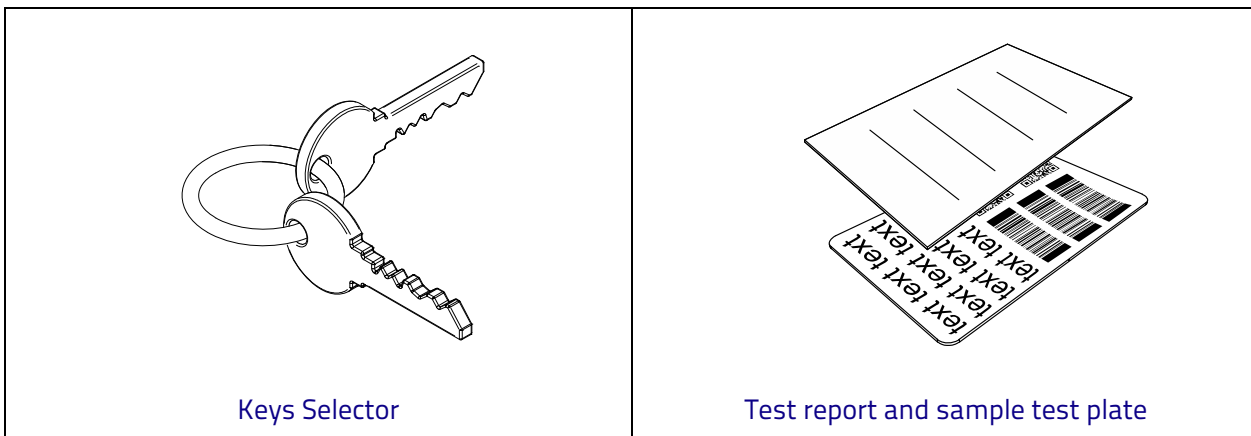
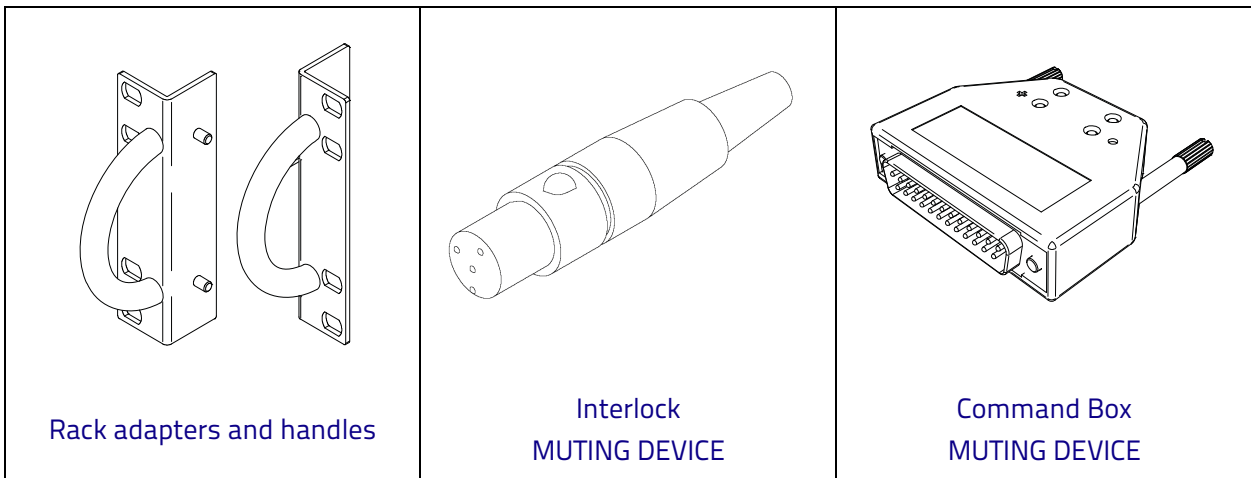
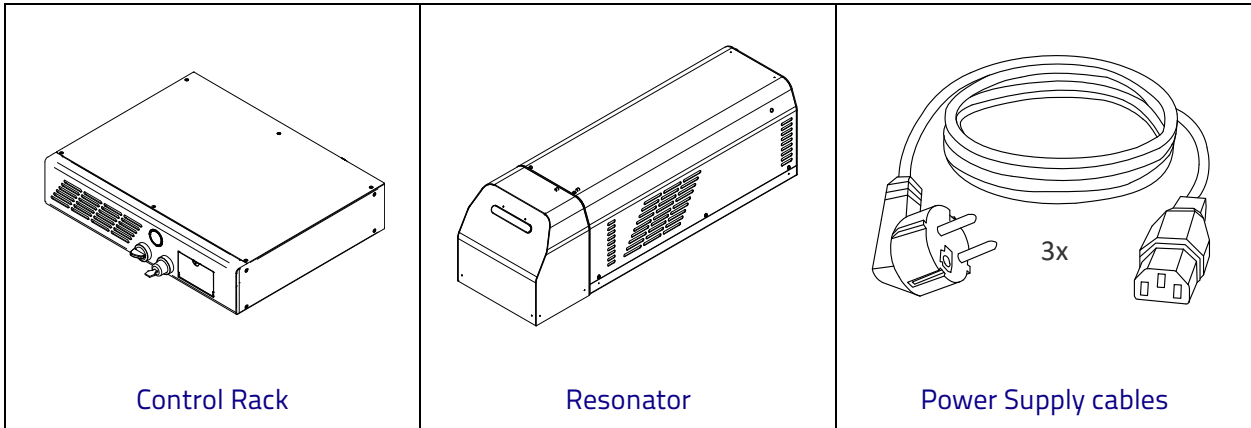

Figure 1: Unpacking

Keep all packing materials until the laser has been inspected for completeness and damage. If something is missing or defective, call Datalogic (see 'Technical Support' on page vi for contact details).

Be sure to use the original packaging material for the transportation of this laser marker, otherwise transportation could cause malfunctions or damage. Keep the original packaging materials for future use. Be careful to ship the laser marker following the recommendations present in the packaging labels.

CONTENTS OF THE PACKAGING



ON MOISTURE CONDENSATION

If the laser marker is brought directly from a cold to a warm location, moisture may condense inside or outside the laser product. This moisture condensation may cause a malfunction of the laser marker.

Note on moisture condensation

Moisture may condense when you bring the laser marker from a cold place into a warm place (or vice versa) and when you use the laser marker in a humid place.

If moisture condensation occurs

Turn off the laser marker and wait about 1 hour for the moisture to evaporate.

How to avoid moisture condensation

Before moving the laser marker from a cold place into a warm place, put it in a plastic bag and seal it tightly. Remove the bag when the air temperature inside the plastic bag has reached the ambient temperature (after about 1 hour).

FIXING AND POSITIONING



CAUTION: Fix the laser marker according to instructions shown in the figures.



CAUTION: It is mandatory to secure the laser marker before you start marking, since improper securing or positioning may cause serious damage.

Do not secure the laser marker in a way other than the one described in the figure.



CAUTION: Introduction of optical or mechanical surfaces, such as mechanical shutters or additional protective glass, between F-Theta scan lens output and marking surface may cause optical feedback into the laser marker.

Optical induced damage caused to laser marker by reflection from external surfaces is not covered by warranty.



NOTE: In order to prevent marking distortions, avoid vibrations and bumps during the marking process!



NOTE: It is recommended to install the scan head on a positioning Z-axis system for accurate mounting at focal distance!



NOTE: The resonator can be fixed either vertically or horizontally.

CONTROL RACK

The control rack can be fitted inside a special rack cabinet equipped with special support shoulders.

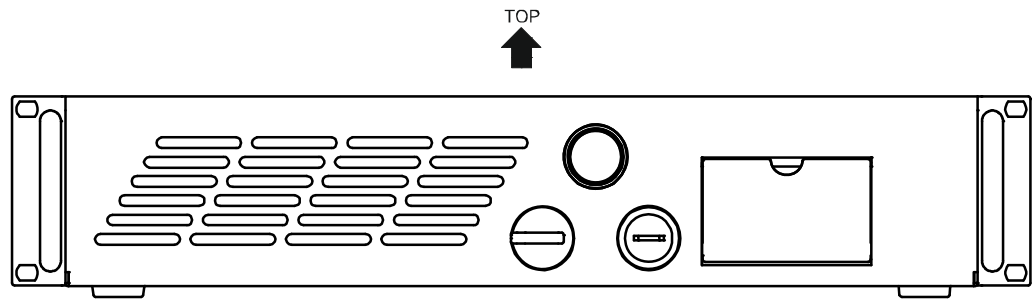

Figure 2: Positioning rack

Here are the odds of the mounting points for mounting in rack:

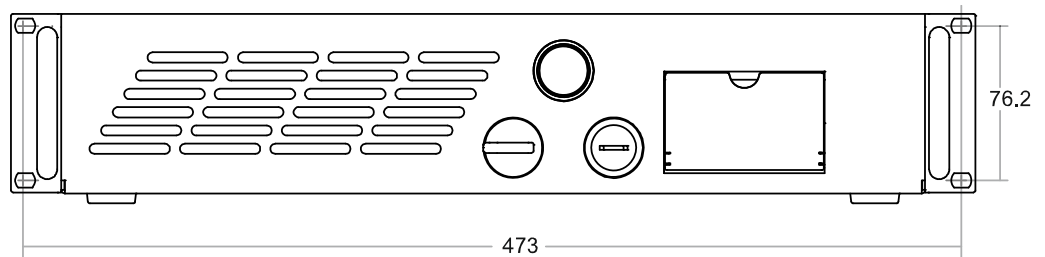

Figure 3: Fixing points on shrug rack (cabinet assembly)



NOTE: All dimensions are in millimeters.

RESONATOR

The resonator must be safely positioned and instructions below must be followed.

The resonator must be secured to a suitable base (not supplied by Datalogic) using the four M6 threaded holes:

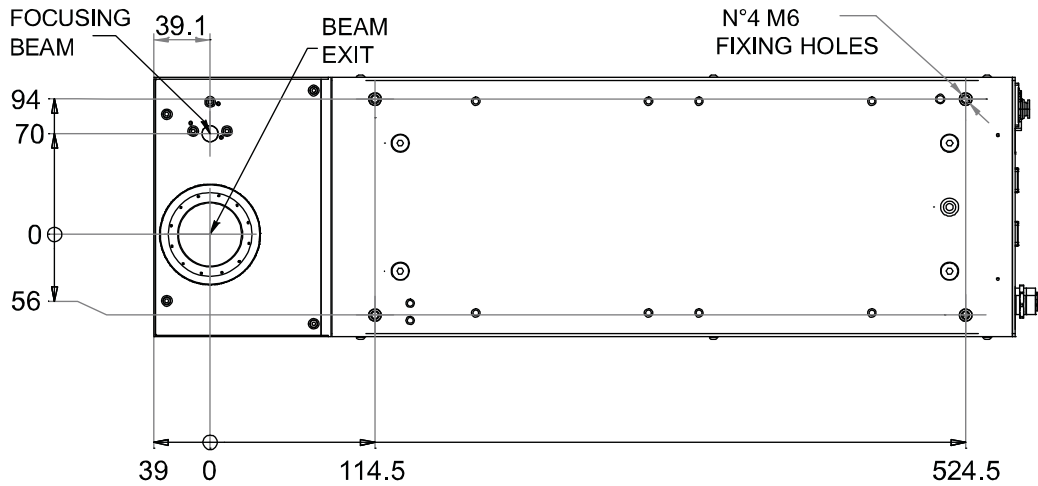

Figure 4: Fixing points



NOTE: All dimensions are in millimeters.

Mounting screws length

To determine the length of the mounting screws, consider the thickness of the mounting plate and the thickness of the washer.

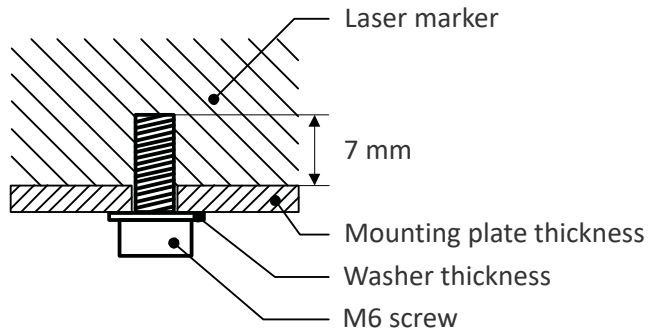

Figure 5: Length of mounting screws



NOTE: Mounting holes depth is = 7mm. Tightening torque = 2 Nm.

INSTALLATION ENVIRONMENT

The laser marker must be installed in a suitable environment in order to allow proper air flow and correct housing of the cables.

The laser marker uses a forced air cooling system: an adequate air flow is necessary to guarantee its correct cooling. Install the laser marker so that air flow is not obstructed. Moreover, do not install it near a heat source.



CAUTION: If not enough space is provided, the temperature inside the laser marker could rise, causing temperature error.

Clean the main fan and the cover when they are dirty. If the main fan and the cover are dirty, insufficient air-flow might not ensure correct cooling and might stop the marking operation. Clean the main fan and the cover periodically.

Control Rack

The control rack must be installed in a suitable environment in order to allow proper air flow passage and correct housing of the cables. Proper air flow can only be guaranteed by assembling the cooling fans correctly:

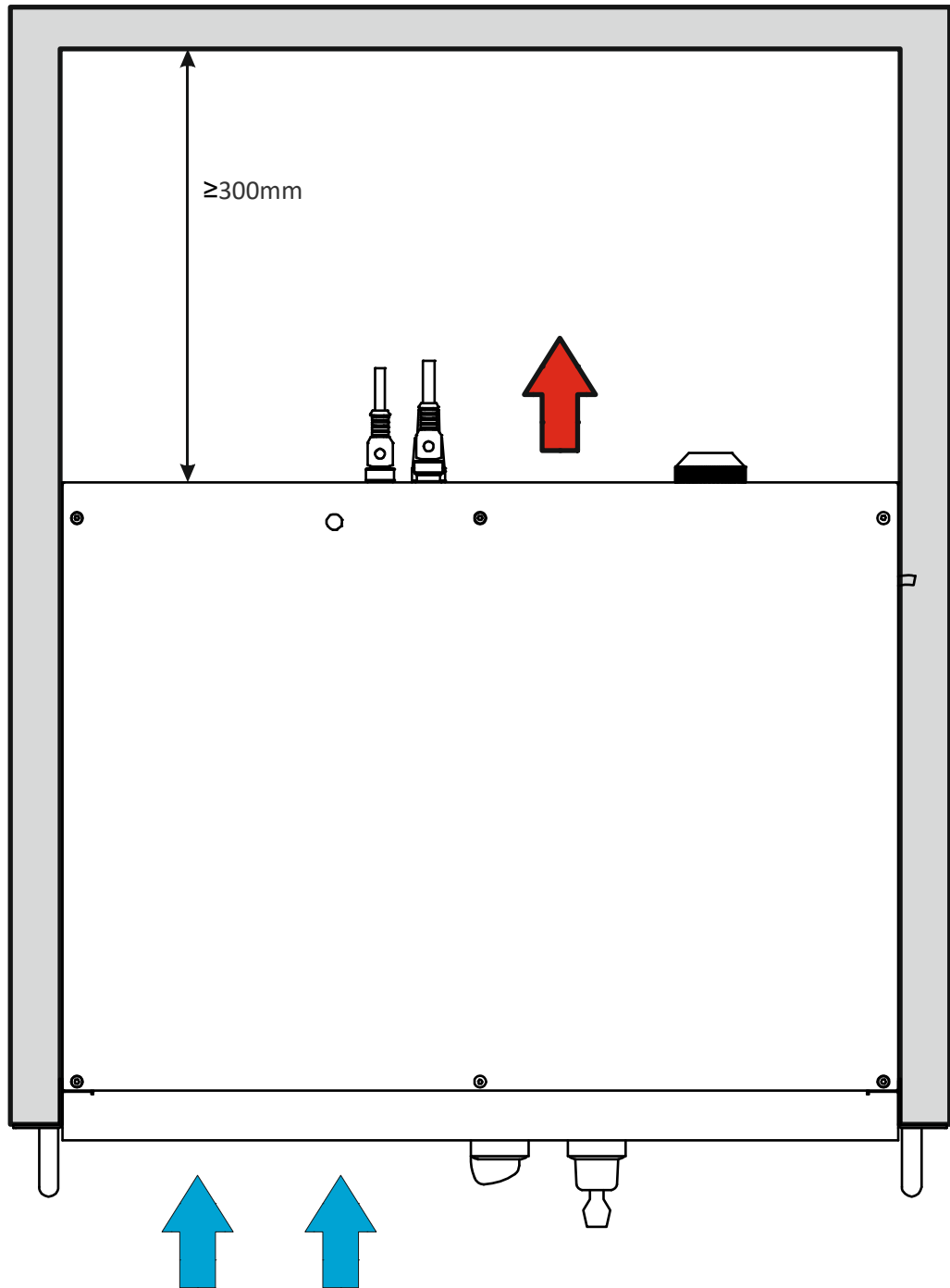

Figure 6: Control rack installation environment



CAUTION: DO NOT place heavy objects on top of the control rack!

Resonator

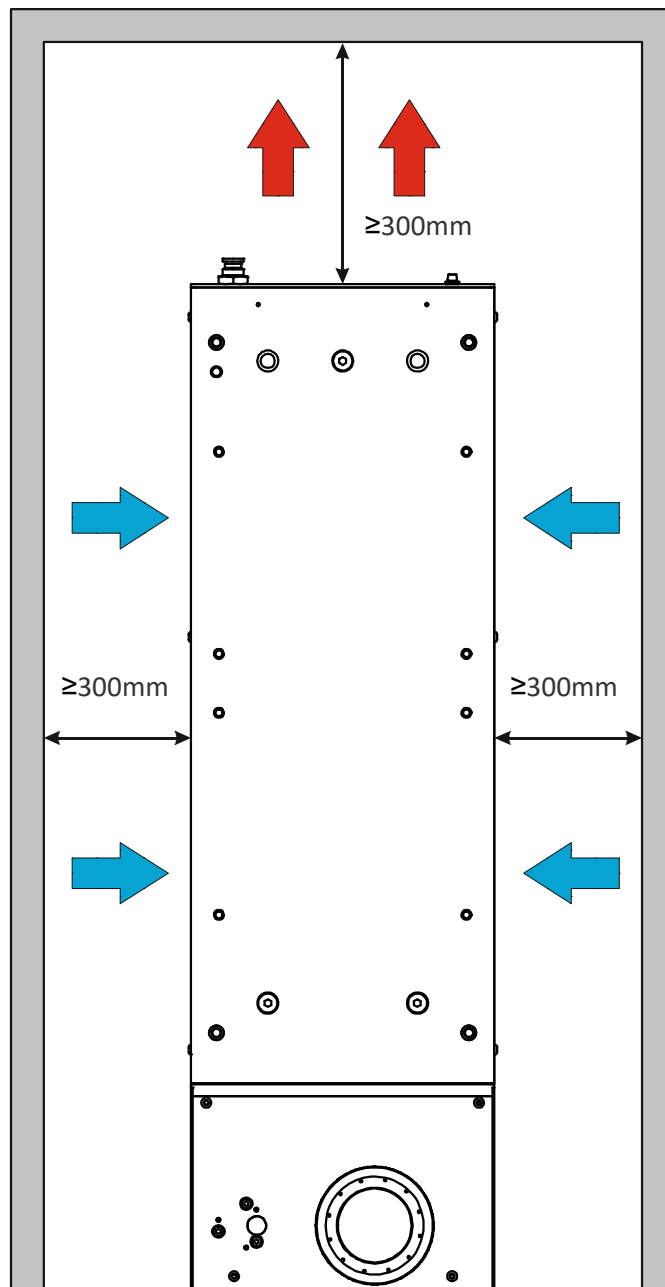

Figure 7: Resonator installation environment

FUME / DUST EXTRACTOR

During the marking process, dust and/or fume may be produced. It is important to use an adequate fume/dust extractor and/or air filtration (see “Fume Extractor” on page 71).



CAUTION: Marking PVC (or other plastic material) can cause the release of chlorine gas which can be harmful to the laser operator and to the laser marker itself. Always use adequate fume extractor during PVC and plastic marking.

CHAPTER 3

TECHNICAL SPECIFICATIONS

TECHNICAL CHARACTERISTICS

EOX MODELS		6302-1X41
ELECTRICAL SPECIFICATIONS		
Input Voltage (main power supply)	V (AC)	100 to 240 @ 50-60 Hz
Max. Input Current (main power supply)	A	2.5
Max power	W	600
LASER SPECIFICATIONS¹		
Laser Type		CO2 sealed laser tube
Average Power ²	W	30
Stability		± 5% (cold start); ± 3% (after 2 minutes works)
Wavelength	µm	10.57 - 10.63
Range Frequency	Hz	10 to 25000; CW
Rise time	µs	< 100
Standard Bexp		2x
Laser Aiming Beam / Focus Beam		Class 2 1mW @ 635 nm ±5
ENVIRONMENTAL SPECIFICATIONS		
Operating Temperature	C (F)	15° to 35° (59° to 95°)
Storage Temperature	C (F)	-10° to 60° (14° to 140°)
Humidity	%	< 95 without condensation
PHYSICAL SPECIFICATIONS		
Control Rack dimensions (HxWxD)	mm in	88.5x430x335 3.48x17x13.1
Control Rack weight	Kg lbs	9 19.8
Control Rack IP Rating		21
Control Rack cooling		Forced Air Fan: L10@40°C = 70000 h

EOX MODELS		6302-1X41
Resonator dimensions (HxWxD) ³	mm	185x180x634
	in	7.3x7.1x24.9
Resonator weight	Kg	17
	lbs	37.5
Resonator IP Rating ⁴		IP21
Resonator cooling		Forced Air Fan: L10@25°C = 100000 h
OTHER SPECIFICATIONS		
Marking speed ⁵	mm/s	Up to 2000
Char Marking Speed ⁶	char/s	Up to 500
MOF (marking on fly)		YES (constant speed or encoder)
Line speed - Productivity ⁶	m/min	Up to 75
	pcs/s	4
Marking Control and Software		EMC (Embedded Marking Control) and Lighter™ Suite
Communication		4x USB, RS232, Ethernet (TCP/IP 10, 100 Mbit), EtherNet/IP, ProfiNet I/O, TcpServer Protocol, Digital I/O

1. Specification @ 25°C
2. Measured at resonator exit
3. Without F-Theta scan lens
4. In horizontal position only
5. May vary: measured with $f = 200\text{mm}$
6. Single line string, Roman-s font

PRODUCT DESCRIPTION

Control Rack

A description of the main parts of the control rack is provided here below:

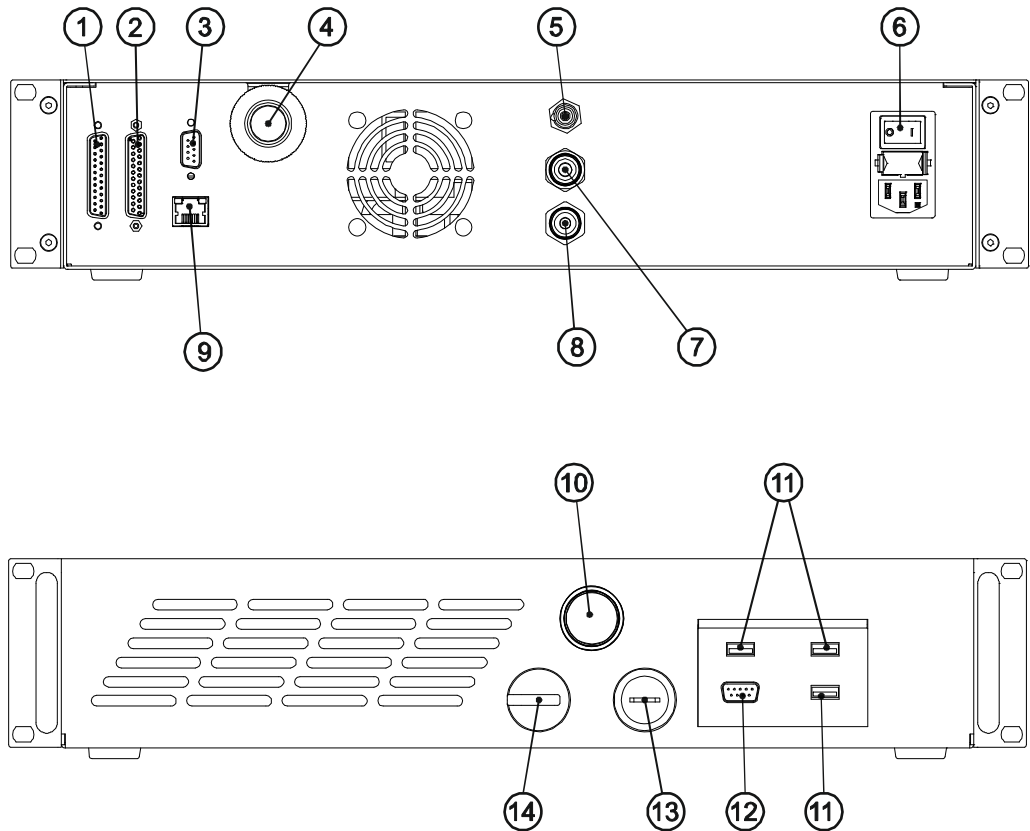

Figure 8: Control rack overview

1. X1 - Command Box Connector (Laser Control)
2. X2 - Axes Connector (I/O Control)
3. RS232 port
4. Resonator cable
5. Interlock connector
6. Main Switch
7. Encoder connector
8. Photocell connector
9. LAN port
10. Status LED
11. USB ports
12. VGA connector
13. Key Selector
14. Enable Selector

Resonator

A description of the main parts of the resonator is provided here below:

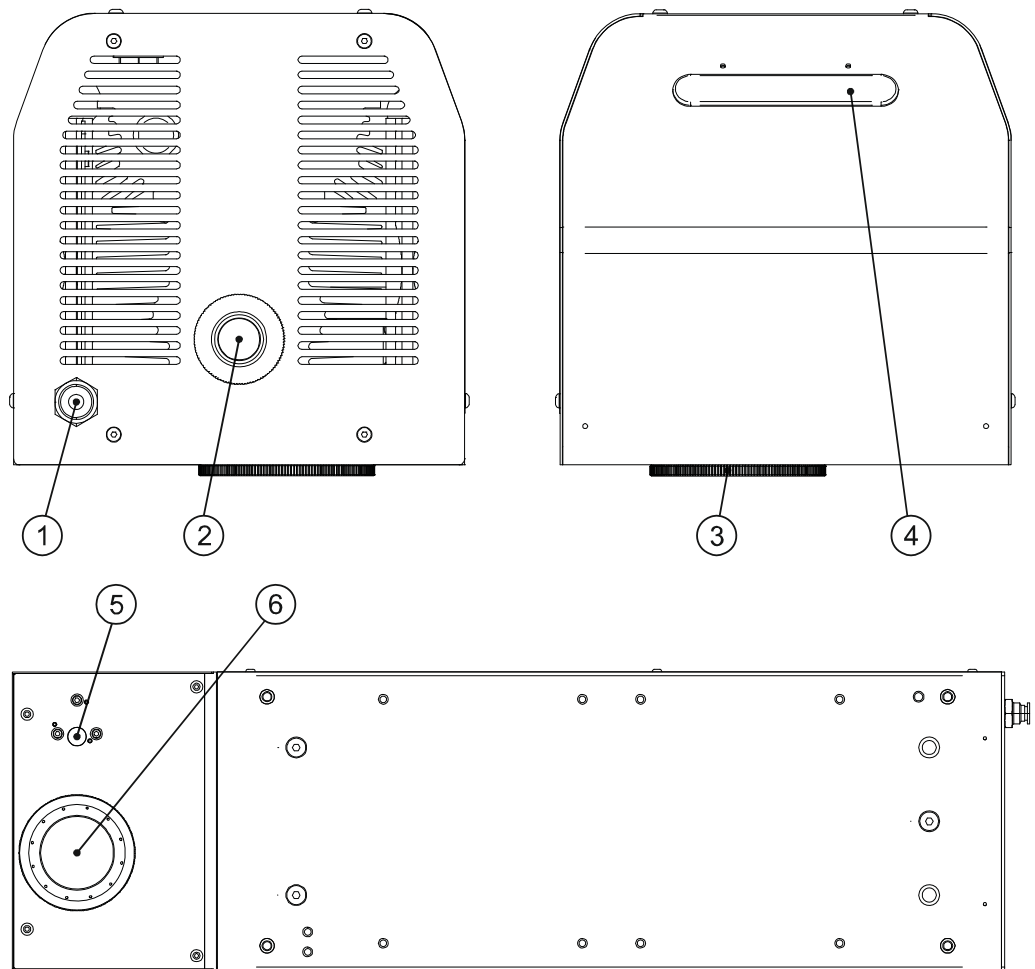

Figure 9: Resonator overview

1. Air inlet (max 1,5 bar)
2. Resonator cable
3. F-Theta Scan Lens with air compressed issue holes
4. Status LED bar
5. Focusing beam
6. Laser beam output / Aiming laser beam output

MARKING AREA SPECIFICATION

Datalogic provides a wide range of laser marker models with different F-Theta scan lenses configurations.

These configurations are provided to best match customer needs regarding marking field size, working distance and power density.



NOTE: Contact Datalogic if other configurations are necessary.



CAUTION: This product was designed to use only certain configurations of F-Theta scan lens and marking field. If your needs are not satisfied by the currently available F-Theta scan lens configurations please contact Datalogic for a solution. The use of other F-Theta scan lenses or operation outside the specified marking field for a certain F-Theta scan lens configuration can lead to damage of the F-Theta scan lens, scan head or laser source. Such damage is not covered by warranty!

F-Theta Scan Lens

The table below lists the standard F-Theta scan lenses currently available:

F-Theta Scan Lens M55			
F-THETA SCAN LENS		$f = 100$	$f = 200$
Working Distance (WD)	mm	100 ± 2	200 ± 2
Fixing Distance (FD)	mm	104.5 ± 2	204.5 ± 2
Marking Area (MA)	mm ²	70 x 70	140 x 140



NOTE: Working Distance is defined as the distance between the center of the marking area (defined in the focal plane) and the closest mechanical edge of the F-Theta scan lens. Refer to the following figure.



NOTE: Fixing Distance is defined as the distance between the base of the scan head and the marking area. Refer to the following figure.

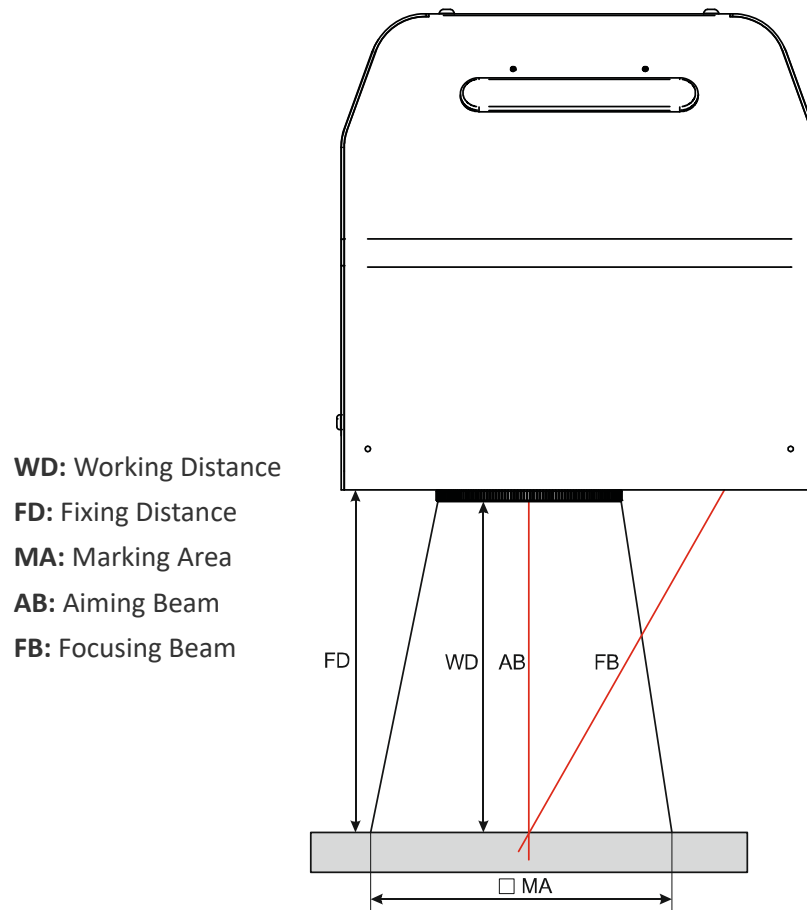

Figure 10: Marking Area



NOTE: The focus position, defined at the point where the focus beam overlaps with the aiming beam, is preset at factory.

CONNECTORS SPECIFICATIONS

Interlock

Interlock **disables** the laser emission.

Control rack back panel connector

Type SWITCHCRAFT TB Series male Tini Q-G (Mini XLR) panel mount connector, 4 positions.

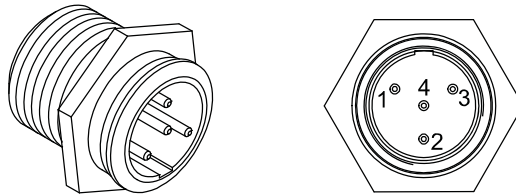

Figure 11: Male panel plug cod. TB4M (front view)

PIN	SIGNAL	TYPE	DESCRIPTION
1	VCC_INT_IN_A	Output	5 V DC reference for INTERLOCK signal A
2	INTERLOCK_A	Input	INTERLOCK signal A
3	GND_INT_IN_B	GND	Ground reference for INTERLOCK signal B
4	INTERLOCK_B	Input	INTERLOCK signal B

Table 1: Connector pinout

PIN1 - PIN2	PIN3 - PIN4	MARKING FUNCTIONALITY	CONDITION
CONTACT OPEN	CONTACT OPEN	NOT POSSIBLE	SAFE
CONTACT CLOSED	CONTACT OPEN	NOT POSSIBLE	DANGEROUS
CONTACT OPEN	CONTACT CLOSED	NOT POSSIBLE	DANGEROUS
CONTACT CLOSED	CONTACT CLOSED	POSSIBLE	DANGEROUS

Table 2: Table of conditions

Electric Diagram

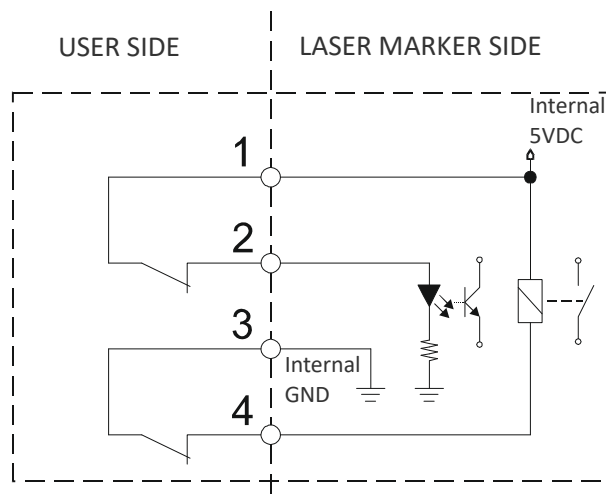

Figure 12: Interlock connector electric diagram

Muting Device

Connector type SWITCHCRAFT TA Series Tini Q-G (Mini XLR) female cable mount connector, 4 positions.

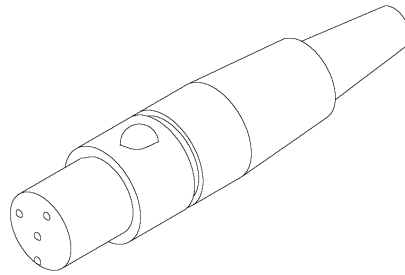

Figure 13: Interlock connector Muting Device provided



CAUTION: Do not use the Interlock Muting Device for external devices, since this will result in loss of the safety function of the machine to which this product is installed.

Do not use the Interlock Muting Device except for maintenance of this product.



CAUTION: It is the customer's responsibility to provide a correct integration of the safety signals according to applicable regulations.

Internal Electric Diagram

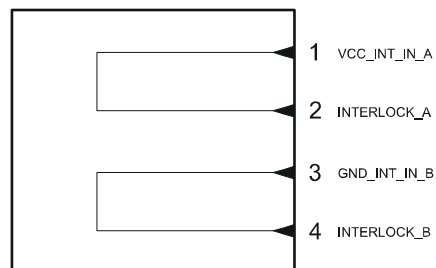

Figure 14: Interlock Muting Device electric diagram

X1 - Command Box (Laser Control)

Control rack back panel connector

Socket Sub-D, 25 pins, female.

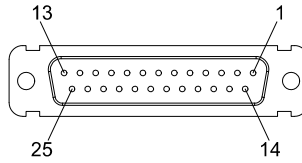

Figure 15: X1 - Command Box connector, female panel socket (front view)

PIN	SIGNAL	TYPE***	DESCRIPTION
X1.1	12V_ENABLE_B	Output power supply	Auxiliary 12V DC power supply available for EXT_ENABLE_B (max 250mA)
X1.2	EXT_ENABLE_B	Digital Input	Secondary external ENABLE signal. This signal is used to open the mechanical Shutter and enable laser emission: - HIGH level: contact closed - LOW level or disconnected: contact opened
X1.3	RESERVED	-	DO NOT CONNECT
X1.4	EXT_12V	Output power supply	Auxiliary 12V DC power supply available for drive input logical HIGH (max 250mA)
X1.5	EXT_12V	Output power supply	Auxiliary 12V DC power supply available for drive input logical HIGH (max 250mA)
X1.6	EXT_12V	Output power supply	Auxiliary 12V DC power supply available for drive input logical HIGH (max 250mA)
X1.7	12V_ENABLE_A	Output power supply	Auxiliary 12V DC power supply available for EXT_ENABLE_A (max 250mA)
X1.8	EXT_ENABLE_A	Digital Input	Primary external ENABLE signal. This signal is used to open the mechanical Shutter and enable laser emission: - HIGH level: contact closed - LOW level or disconnected: contact opened
X1.9	BUSY*	Digital Output	This signal is used to know if the current spooler is executing (marking in progress): - ON during marking process
X1.10	CONNECTOR_PRESENCE	Digital Input	This signal is used to check the presence of the Command Box connector: - HIGH level: normal operation - LOW level or disconnected: laser marker faulty
X1.11	START_MARKING*	Digital Input	This signal is used to start to the marking process when a document or a sequence is running in AUTO MODE** or WORK MODE**: - HIGH level pulsed signal start the marking process
X1.12	EXT_KEY	Digital Input	External KEY signal used to activate the laser source: - HIGH level: contact closed - LOW level or disconnected: contact opened
X1.13	STOP_MARKING*	Digital Input	This signal is used to stop the marking process: - HIGH level pulsed signal stop the marking process
X1.14	CODE3	Digital Input	Generic Input (INPUT 13)
X1.15	CODE2	Digital Input	Generic Input (INPUT 12)
X1.16	CODE1	Digital Input	Generic Input (INPUT 11)
X1.17	END	Digital Output	This signal is used to know if the marking process is finished: - ON at the end of marking process
X1.18	LASER_ACTIVE	Digital Output	This signal is used to know if the laser source is activated: - ON when the laser is in STAND_BY or READY state
X1.19	GND	Ground	Ground reference
X1.20	SYSTEM_ALARM	Digital Output	This signal is used to know if the laser marker is in error state: - ON in case of system error

PIN	SIGNAL	TYPE***	DESCRIPTION
X1.21	GND	Ground	Ground reference
X1.22	SHUTTER_OPEN	Digital Output	This signal is used to know if the laser marker is ready to emit laser radiation: - ON when the laser marker is in READY state and Shutter is opened
X1.23	SW_READY*	Digital Output	Depending on the configuration this signal can be used in different ways: - COMPATIBILITY: ON when a document or a sequence is running in AUTO MODE** or WORK MODE** independently from the laser marker state. The signal is ON regardless of whether the laser marker is ready to start a new marking - STANDARD: ON when a document or a sequence is running in AUTO MODE** or WORK MODE** and the laser marker state is READY. The signal is ON regardless of whether the laser marker is ready to start a new marking. (a capo) This signal can also be driven using Lighter™ Script engine "IoPort.setReady(true)" function
X1.24	GND	Ground	Ground reference
X1.25	GND	Ground	Ground reference

Table 3: X1 - Command Box connector pinout

(*) refers to Lighter™ user's manual "Setting I/O parameters" paragraph to set the signal properties

(**) refers to Lighter™ user's manual

(***) see "Input/Output specifications" on page 31

PIN1 - PIN2	PIN7 - PIN8	MARKING FUNCTIONALITY	CONDITION
CONTACT OPEN	CONTACT OPEN	NOT POSSIBLE	SAFE
CONTACT CLOSED	CONTACT OPEN	NOT POSSIBLE	DANGEROUS
CONTACT OPEN	CONTACT CLOSED	NOT POSSIBLE	DANGEROUS
CONTACT CLOSED	CONTACT CLOSED	POSSIBLE	DANGEROUS

Table 4: Table of conditions



NOTE: The response time is 250ms from the input's switching.

Muting Device

Sub-D, 25 pins, male, with shell.

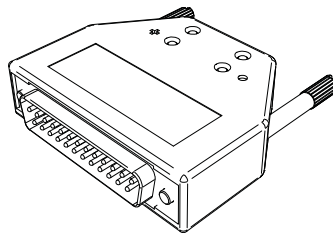

Figure 16: Command Box Muting Device provided

Internal electric diagram

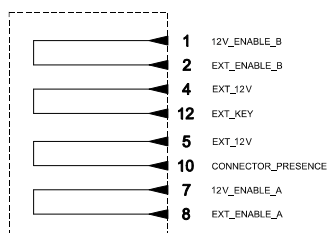

Figure 17: Command Box Muting Device electric diagram

X2 - Axes (I/O Control)

Control rack back panel connector

Plug Sub-D, 25 pins, male.

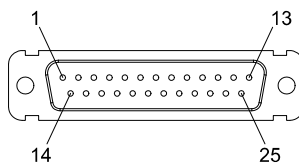

Figure 18: X2 - Axes connector, male panel plug (front view)

PIN	SIGNAL **	TYPE***	DESCRIPTION
X2.1	EXT_12V	Output Power supply	Auxiliary 12V DC power supply available for drive input logical HIGH (max 205mA)
X2.2	OUTPUT_0 (*) or STEP_Y	Digital Output	Generic output or Y-Axis drive step signal (Clock) for axis control (**)
X2.3	OUTPUT_2 (*) or STEP_Z	Digital Output	Generic output or Z-Axis drive step signal (Clock) for axis control (**)
X2.4	OUTPUT_4 (*) or BRAKE X	Digital Output	Generic output or X-Axis electromechanical brake release signal. ON during drive motion
X2.5	OUTPUT_6 (*) or BRAKE Y	Digital Output	Generic output or Y-Axis electromechanical brake release signal. ON during drive motion
X2.6	OUTPUT_8 (*) or BRAKE Z	Digital Output	Generic output or Z-Axis electromechanical brake release signal. ON during drive motion
X2.7	INPUT_0 (*) or ZERO X	Digital Input	Generic input or X-Axis home sensor input. The home search is stopped when this signal goes HIGH
X2.8	INPUT_1 (*) or ZERO Y	Digital Input	Generic input or Y-Axis home sensor input. The home search is stopped when this signal goes HIGH
X2.9	INPUT_2 (*) or ZERO Z	Digital Input	Generic input or Z-Axis home sensor input. The home search is stopped when this signal goes HIGH
X2.10	INPUT_3 (*) or DISABLE X	Digital Input	Generic input or X-Axis disable signal. When HIGH, the corresponding step signal remains in the state prior to activation
X2.11	INPUT_4 (*) or DISABLE Y	Digital Input	Generic input or Y-Axis disable signal. When HIGH, the corresponding step signal remains in the state prior to activation
X2.12	INPUT_5 (*) or DISABLE Z	Digital Input	Generic input or Z-Axis disable signal. When HIGH, the corresponding step signal remains in the state prior to activation
X2.13	GND	Ground	Ground reference
X2.14	OUTPUT_12 (*) or STEP R	Digital Output	Generic output or R-Axis drive step signal (Clock) for axis control
X2.15	OUTPUT_1 (*) or STEP X	Digital Output	Generic output or X-Axis drive step signal (Clock) for axis control
X2.16	OUTPUT_3 (*) or DIR Z	Digital Output	Generic output or Z-Axis drive direction signal
X2.17	OUTPUT_5 (*) or DIR Y	Digital Output	Generic output or Y-Axis drive direction signal
X2.18	OUTPUT_7 (*) or DIR X	Digital Output	Generic output or X-Axis drive direction signal
X2.19	INPUT 9	Digital Input	Generic Input
X2.20	INPUT 8	Digital Input	Generic Input
X2.21	INPUT_7 (*) or ZERO R	Digital Input	Generic input or R-Axis home sensor input. The home search is stopped when this signal goes HIGH
X2.22	INPUT_6 (*) or DISABLE R	Digital Input	Generic input or R-Axis disable signal. When HIGH, the corresponding step signal remains in the state prior to activation
X2.23	OUTPUT_9 (*) or BRAKE R	Digital Output	Generic output or R-Axis electromechanical brake release signal. ON during drive motion
X2.24	OUTPUT_11 (*) or DIR R	Digital Output	Generic output or R-Axis drive direction signal
X2.25	GND	Ground	Ground reference

Table 5: X2 - Axes connector pinout

(*) enabling an axis causes the corresponding control signals to no longer be available as generic inputs/outputs. Refer to Lighter™ user's manual, "Setting the X, Y, Z, and Rotor Axes parameters" to enable/disable Axes and set the Axes properties

(**) see "Axes I/O signals behavior" on page 37

(***) see "Input/Output specifications" on page 31

Encoder

Control rack back panel connector

Socket, M12, 8 pins female. Recommended encoder: incremental Encoder PNP, M12, 8 pins, push/pull outputs AB0 only, 10-30 VDC.

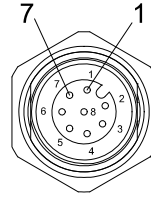

Figure 19: Encoder connector, female panel socket (front view)

PIN	SIGNAL	TYPE*	DESCRIPTION
1	GND	Ground	Ground reference
2	VCC	Power Output	Auxiliary 12V DC power supply
3	ENC_A	Digital input	Encoder HTL A channel signal
4	GND	Ground	Return signal for ENC_A
5	ENC_B	Digital Input	Encoder HTL B channel signal
6	GND	Ground	Return signal for ENC_B
7	RESERVED	-	DO NOT CONNECT
8	RESERVED	-	DO NOT CONNECT
BODY	SHIELD	Shield	Shield

Table 6: Encoder connector pinout

(*) see "Input/Output specifications" on page 31

Photocell

Control rack back panel connector

Socket, M12, 4 pins female. Recommended photocell: Datalogic S51-PA-5-B01-PK; Datalogic S15-PA-5-B01-PK or equivalent.

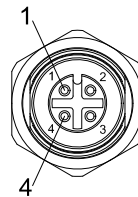

Figure 20: Photocell connector, female panel socket (front view)

PIN	SIGNAL	TYPE*	DESCRIPTION
1	VCC	Power Supply	Auxiliary 12V DC power supply (120mA max)
2	RESERVED	-	DO NOT CONNECT
3	GND	Ground	Ground reference
4	PHOTOCELL	Digital input	PNP photocell signal

Table 7: Photocell connector pinout

(*) see "Input/Output specifications" on page 31

RS232



NOTE: Depending on the system S/N the serial port can be mapped as COM2 or COM3. Contact Datalogic Technical Support for more details (see “Technical Support” on page vi for contact details).

Control rack back panel connector

Plug Sub-D, 9 pins, male.

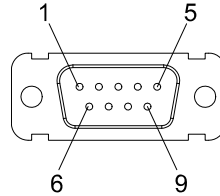

Figure 21: RS232 connector, male panel plug (front view)

PIN	SIGNAL	TYPE	DESCRIPTION
1	DCD	Input	Data Carrier Detect
2	RXD	Input	Receive Data
3	TXD	Output	Transmit Data
4	DTR	Output	Data Terminal Ready
5	GND	Ground	Ground reference
6	DSR	Input	Data Set Ready
7	RTS	Output	Request To Send
8	CTS	Input	Clear To Send
9	RI	Input	Ring Indicator

Table 8: Standard RS232 connector pinout

INPUT/OUTPUT SPECIFICATIONS

Digital Input

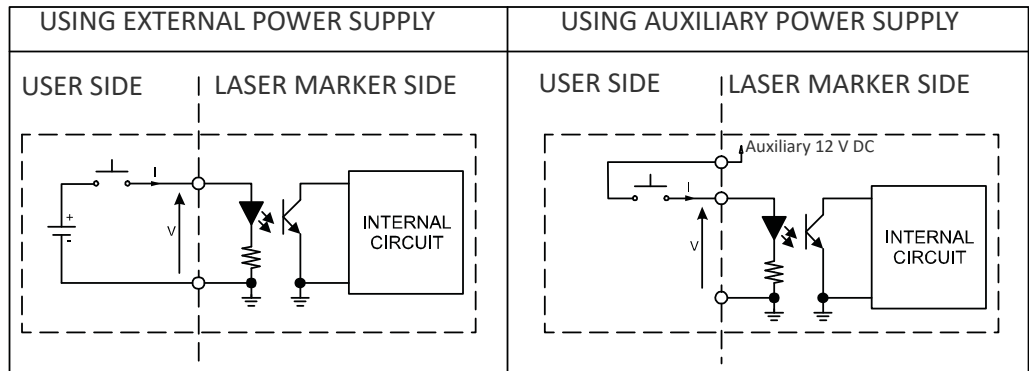

TECHNICAL CHARACTERISTICS			
Type	Optocoupler		
Vmax	24 V DC		
I _{max}	5 mA @ 24 V DC		
Pulse Width	≥ 1 ms (debounce)		
	MIN	TYP	MAX
INPUT Logic LOW	0.0 V DC	0.0 V DC	2.0 V DC
INPUT Logic HIGH	5.0 V DC	12.0 V DC	24.0 V DC

Table 9: Digital Input specification

Digital Output

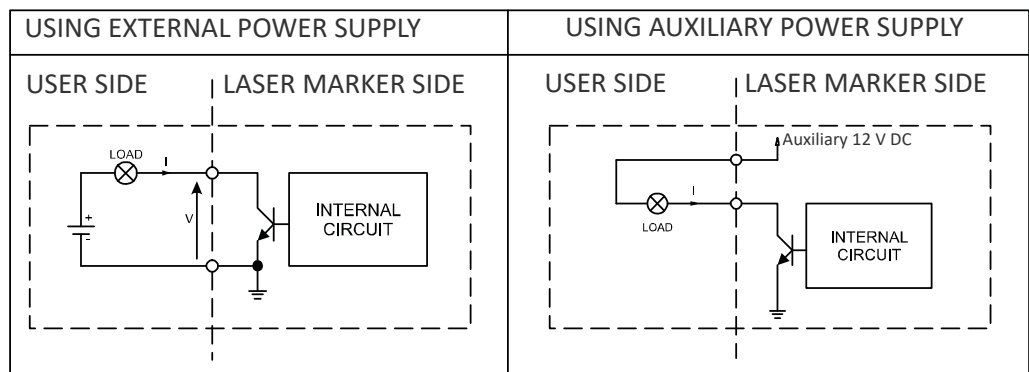







TECHNICAL CHARACTERISTICS	
Type	Low side driver
Vmax	24 V DC
I _{max}	250 mA
V _{saturation}	<0.5 V DC
Leakage current	< 5 μA
LOW Level Output	V ≤ 0.5 V DC; I ≤ 250 mA
HIGH Level Output	V ≤ 24 V DC; I ≤ 5 μA

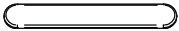
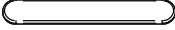

Table 10: Digital Output specification

LASER MARKER STATES



Normal Operation States

STATE	DESCRIPTION	STATUS LED
SYSTEM BOOTING UP	This state occurs since the laser marker is switched on until Laser Engine has been loaded and no errors occurred	Control rack  Blinking
		Resonator  OFF
WAIT FOR START	In this state the laser marker cannot emit IR lasers radiation and Aiming and Focus beam can be activated	Control rack  Steady
		Resonator  OFF
STANDBY SHUTTER CLOSED	In this state Aiming and Focus beam can be activated while the laser marker cannot emit IR laser radiation	Control rack  Steady
		Resonator  Steady
READY	In this state the laser marker is able to emit IR laser radiation	Control rack  Steady
		Resonator  Steady

Error States







STATE	DESCRIPTION	STATUS LED
INTERLOCK ERROR	This error occurs if the INTERLOCK safety function is ON. To reset the error, set INTERLOCK safety function to OFF and repeat the turning on sequence	Control rack  Blinking
		Resonator  OFF
INTERLOCK ERROR	This error occurs if the CONNECTOR_PRESENCE signal (pin X1.10 Command Box connector) is LOW or not connected. To reset the error, set CONNECTOR_PRESENCE signal to HIGH value and repeat the turning on sequence	Control rack  Blinking
SHUTTER ERROR	This error occurs when the shutter mechanism is not working properly	Resonator 
RESONATOR ERROR	This error occurs when one of the following errors is detected in the laser source: temperature error, power supply error, internal failure	Blinking

Warning State

STATE	DESCRIPTION	STATUS LED
WARNING INVALID START SEQUENCE	This state occurs if the turning on sequence has not been followed. To restore normal laser marker operation, repeat the turning on sequence	Control rack  Blinking
		Resonator  Blinking

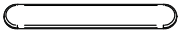
Control the Laser Marker States

The laser marker states can be controlled by X1 - Command Box connector:

STATE	X1 - COMMAND BOX INPUT STATE		STATUS LED
SYSTEM BOOTING UP	EXT_KEY EXT_ENABLE_A EXT_ENABLE_B	LOW LOW LOW	Control rack  Blinking
			Resonator  OFF
WAIT FOR START	EXT_KEY EXT_ENABLE_A EXT_ENABLE_B	LOW LOW LOW	Control rack  Steady
			Resonator  OFF
STANDBY SHUTTER CLOSED	EXT_KEY EXT_ENABLE_A EXT_ENABLE_B	HIGH LOW LOW	Control rack  Steady
			Resonator  Steady
READY	EXT_KEY EXT_ENABLE_A EXT_ENABLE_B	HIGH HIGH HIGH	Control rack  Steady
			Resonator  Steady

TIMING DIAGRAMS

Turning On sequence

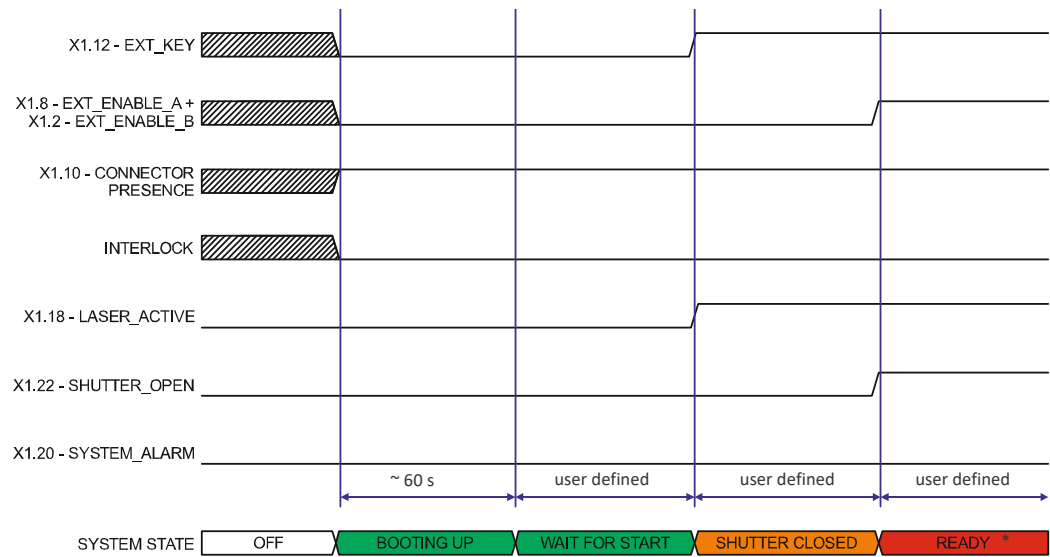

* a maximum delay of 5 to 10 seconds may be present between *ENABLE* activation and laser emission

Figure 22: Turning On sequence timing diagram

Marking control signals behavior

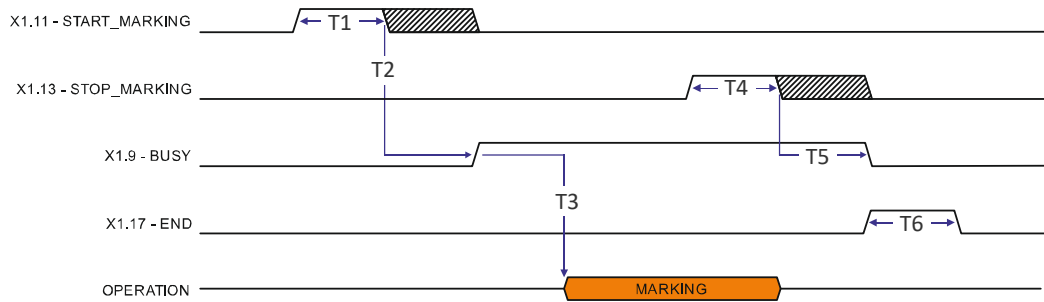

Figure 23: Marking process timing diagram

REF.	NAME	DESCRIPTION
T1	Start Time	Minimum time duration that the START_MARKING signal must have in order to be accepted as a valid START_MARKING event
T2	Start Delay	Delay between the acceptance of the START_MARKING signal and the rising edge of the BUSY signal
T3	Busy Advance	Delay between the rising edge of the BUSY signal and the laser emission
T4	Stop Time	Minimum time duration that the STOP_MARKING signal must have in order to be accepted as a valid STOP_MARKING event
T5	Busy Delay	Delay between the end of the laser emission and the falling edge of the BUSY signal
T6	End Time	Time duration of the END signal



NOTE: Consult Lighter™ software user's manual for a proper use of the same.

Axes I/O signals behavior

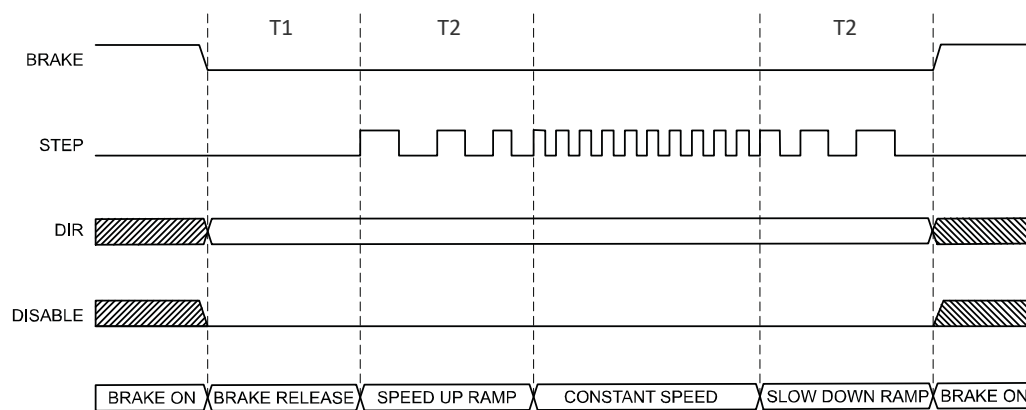

Figure 24: Axes I/O signals behavior

REF.	NAME	DESCRIPTION
T1	Brake release	The time that elapses between the brake release signal activation and the start of mechanical movement
T2	Ramp Time	The time to go from minimum speed (Start speed) to working speed (Speed)

LIGHTER™ SUITE MARKING SOFTWARE

The laser marker is equipped with Lighter™ Suite marking software.

Lighter™ Suite is the all-inclusive editing and laser management software for all Datalogic Laser Marking products.

Lighter™ Suite with its innovative approach focused on the user experience is revolutionizing Laser Marking management; the powerful and simple interface, the flexible and comprehensive customization capabilities and effective production tools represent an important step-ahead in traceability and branding industrial applications.

Lighter™ Suite combines into an unified GUI (Graphical User Interface) a powerful vectorial graphical editor, an advanced laser controller and the innovative MARVIS™ (MARK Read Verify Integrated Solution) feature to seamless interact with AutoID code reader for in-line validation of marked traceability codes.

MARVIS™ connects Datalogic MATRIX™ N-series reader with the laser marker, enabling controlling from one single interface and enhancing individual products' performances.

MARVIS™ is also available as update for existing products.

Object-Oriented Configuration

In the Lighter Suite, each object is associated with specific LASER parameters and READER configuration; loading a graphical layout will automatically retrieve and update laser and reader configurations.

Advanced Editing Function

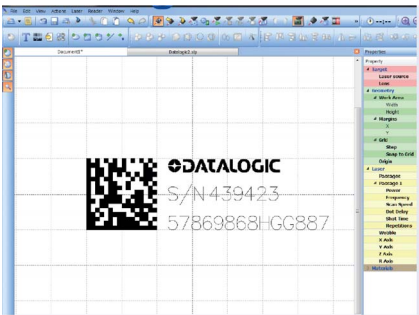
	<ul style="list-style-type: none"> • Easily create, import and edit texts, shapes and logos • One-click code generator for 1D and 2D symbologies • Object-related Property Browser for fast adjustment of Marker and Reader parameters • Imports Bitmap and Vector files (DXF, DWG, PLT, PDF, AI, SVG, BMP, JPG, PNG and TIFF...) • Advanced filling featured with various laser-optimized patterns
---	--

MARVIS™ Integrated Configuration And Setup

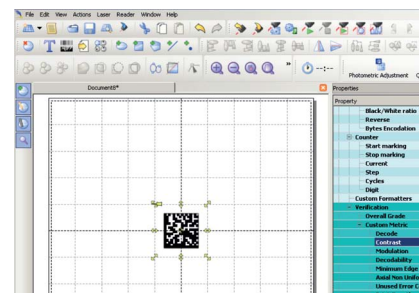
	<ul style="list-style-type: none"> • IP address discovery and connection management • Dedicated Digital output for in-line parts selection • Dedicated Digital input for deferred reader trigger • Configurable images storage pool • New Code Quality Training feature to automatically define code quality threshold from "Golden Sample" • Patent Pending "Quality Grade Metric Profile" (QGP)
---	---

Connectivity

The Lighter™ Suite allows OEMs and Machine builders to develop a complete and cost effective Laser Marking Station, based on embedded hardware and software resources (such as STAND ALONE mode) or to design an advanced Laser Marking Solution able to control machinery over a simple Ethernet connection with a supervisor computer (MASTER-SLAVE mode).

Lighter™ Suite natively embeds TcpServer, Profinet I/O and EtherNet/IP protocols.

Scripting programmability

The LIGHTER Suite integrates the IDE (Integrated Development Environment) providing the users with a full set of tools to be used for extremely flexible customization.

The programming language is ECMAScript (also called JavaScript).

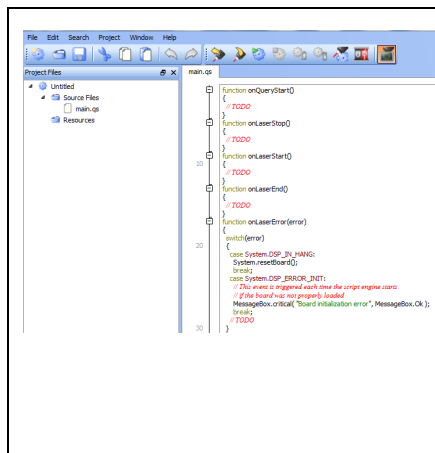

- Control the entire marking process
- Create and fully customize marking layout and its content at runtime
- Interact with local or centralized databases
- Create alternative customized interfaces
- Interact with Third Party devices

Runtime Production Statistics and Reports

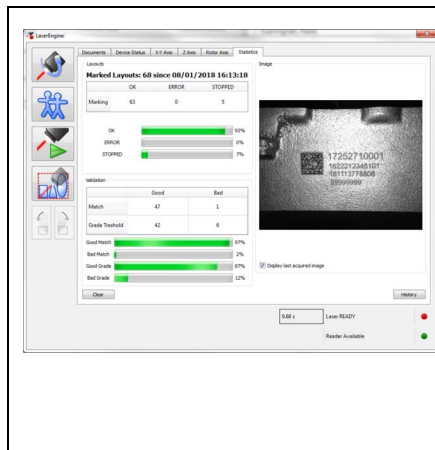

Built-in validation statistics dashboard.

Configurable log file with Quality Reporting and code images.

CHAPTER 4

SET UP

CONNECTIONS

The laser marker connections are described here below. Follow the operations as described.

Control Rack - Resonator connection

In order to connect the resonator to the rack, perform some simple operation:

1. open the control rack. Unscrew the six screws that secure the cover of the rack:

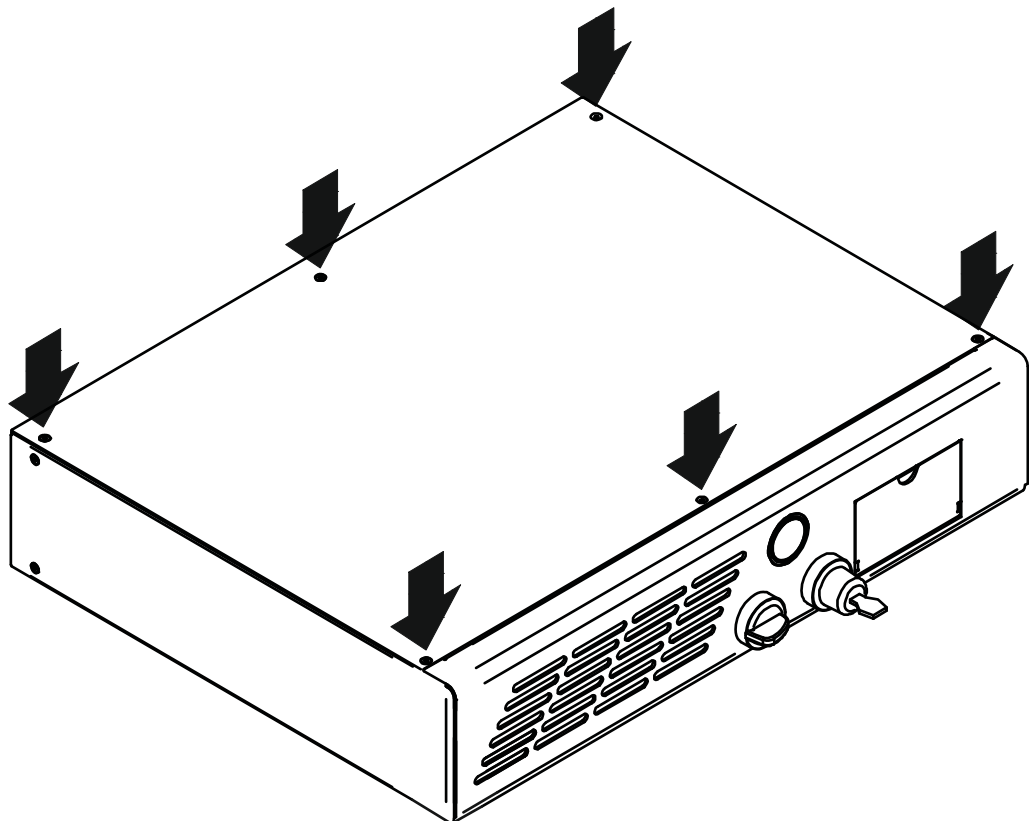

Figure 25: Remove cover screws rack

- hook the cable into the slot on the rack as shown:

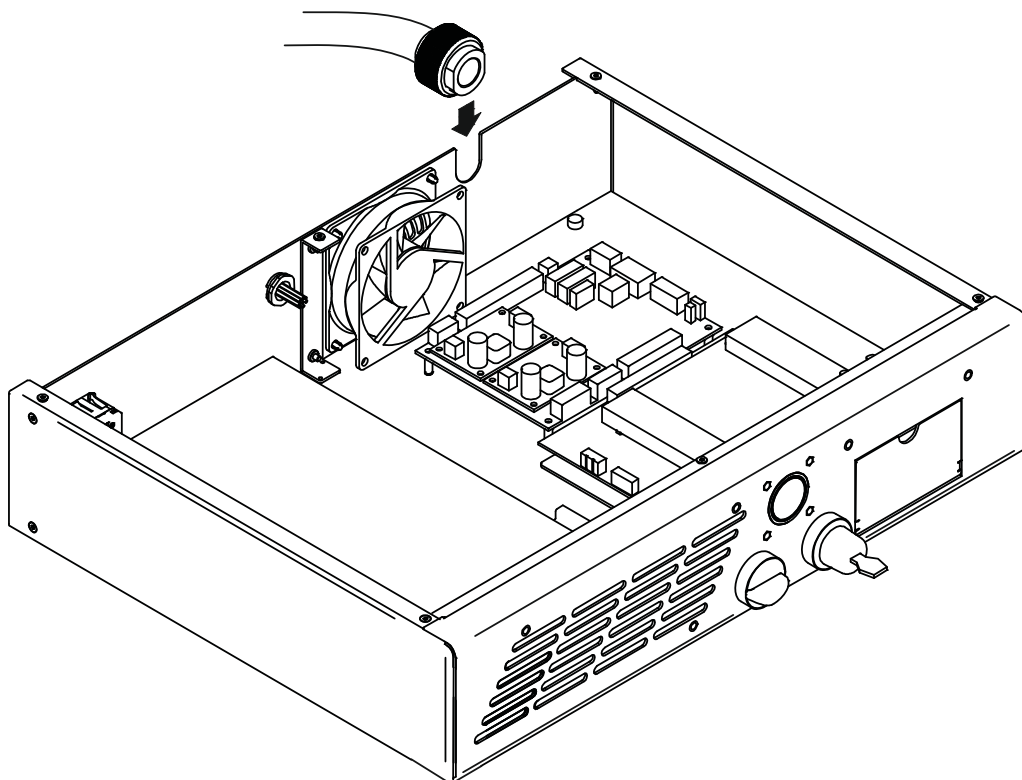

Figure 26: Hooking main cable

- connect rack-resonator signals cable (connector J7):

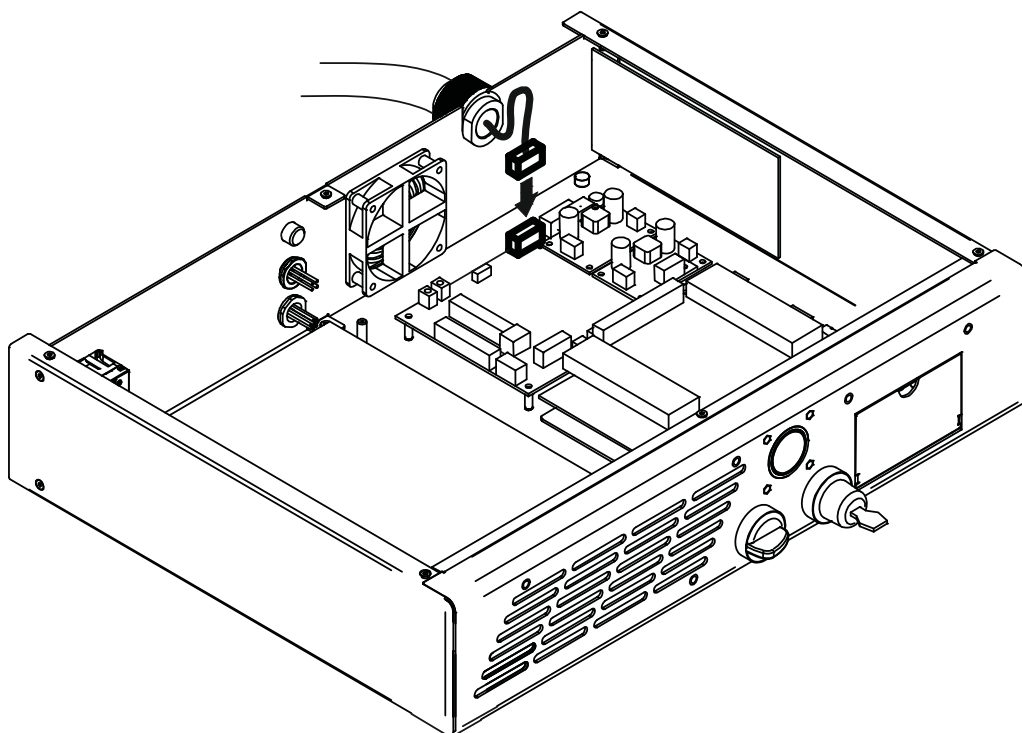

Figure 27: Connection rack-resonator signals cable

- connect female terminal block power supply (+5V and +12V) to male terminal block J18:

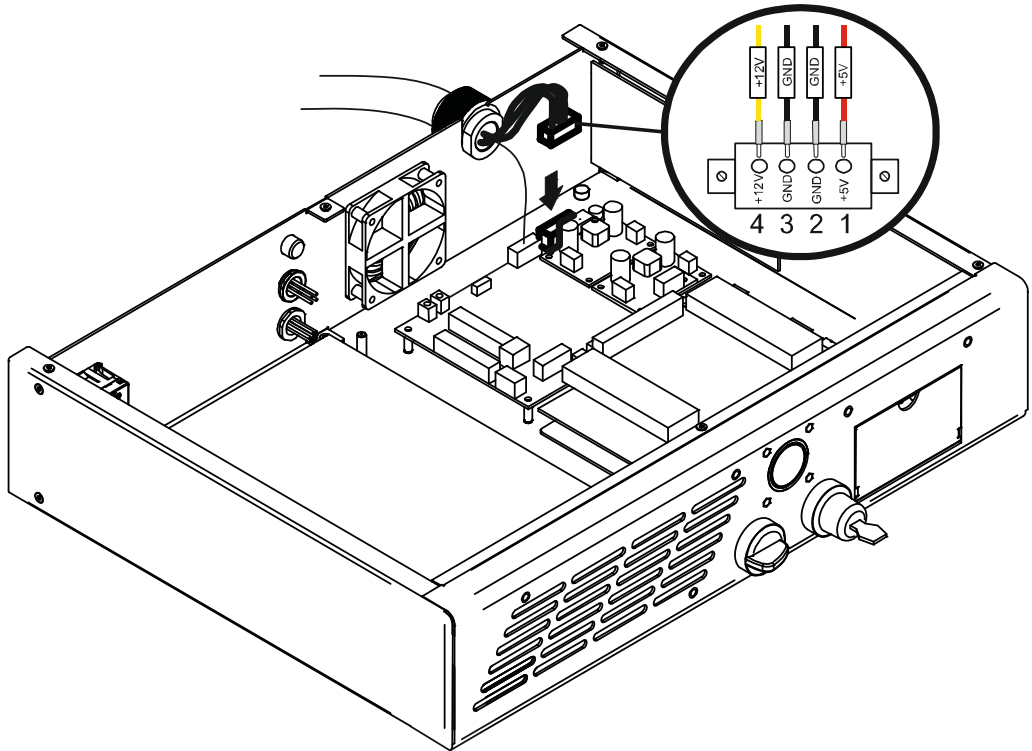

Figure 28: Connection to power supply terminal block (+5V e +12V)

- connect iMark signals cable to iMark board (conn. J2001):

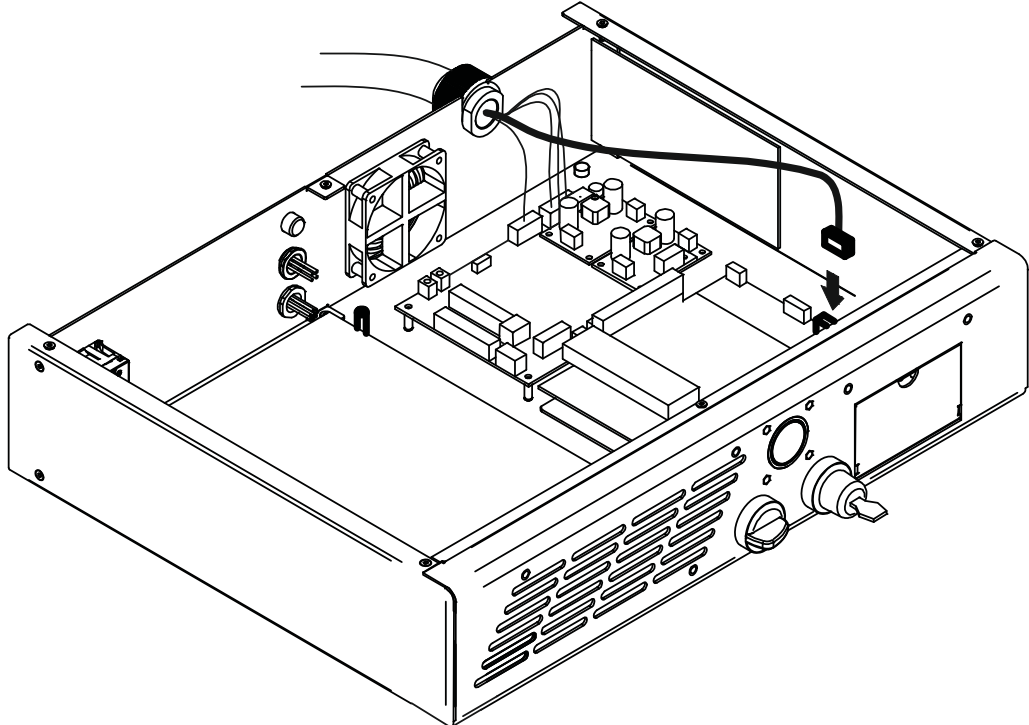

Figure 29: Connection iMark cable

6. connect GND of iMark signals cable to Embedded PC board:

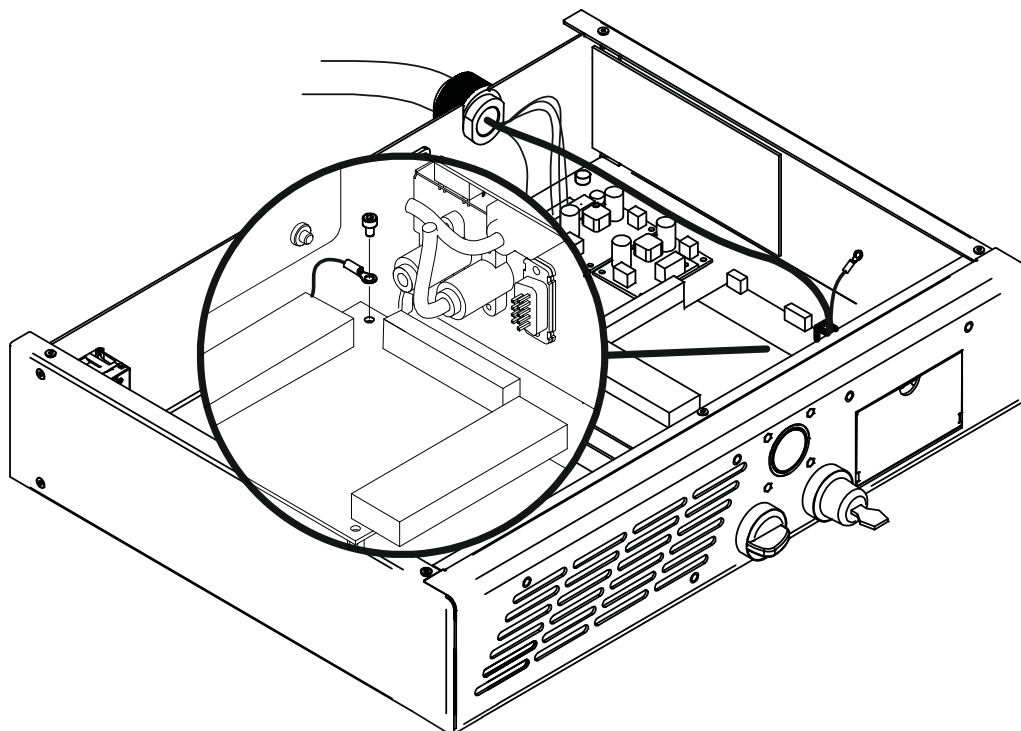

Figure 30: Connection GND of iMark cable

7. connect rack-resonator earth cable to earth PEM site into the rack:

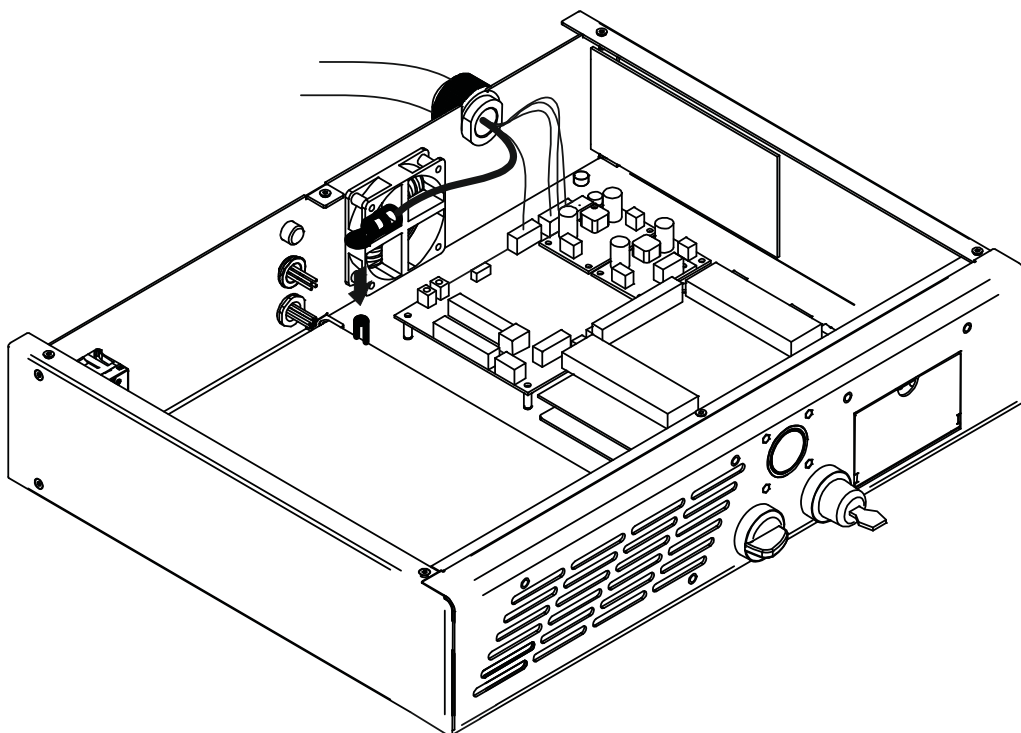

Figure 31: Connection of earth cable on PEM

- connect +30V power supply and GND to dedicate terminal block:

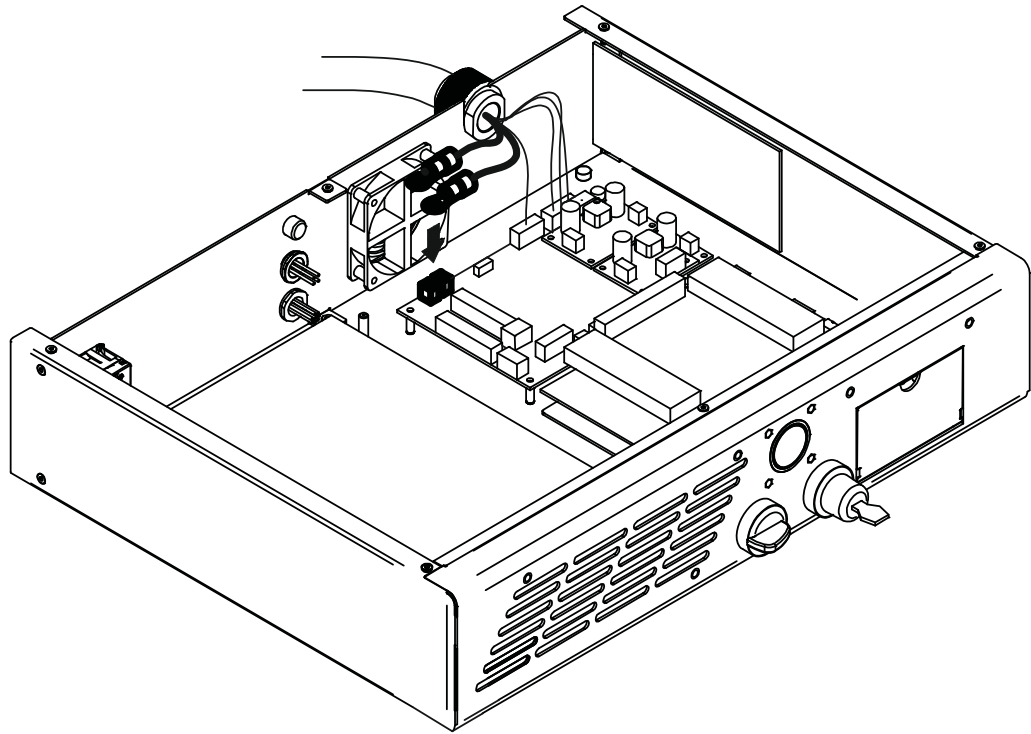

Figure 32: Connect +30V power supply

- close control rack cover:

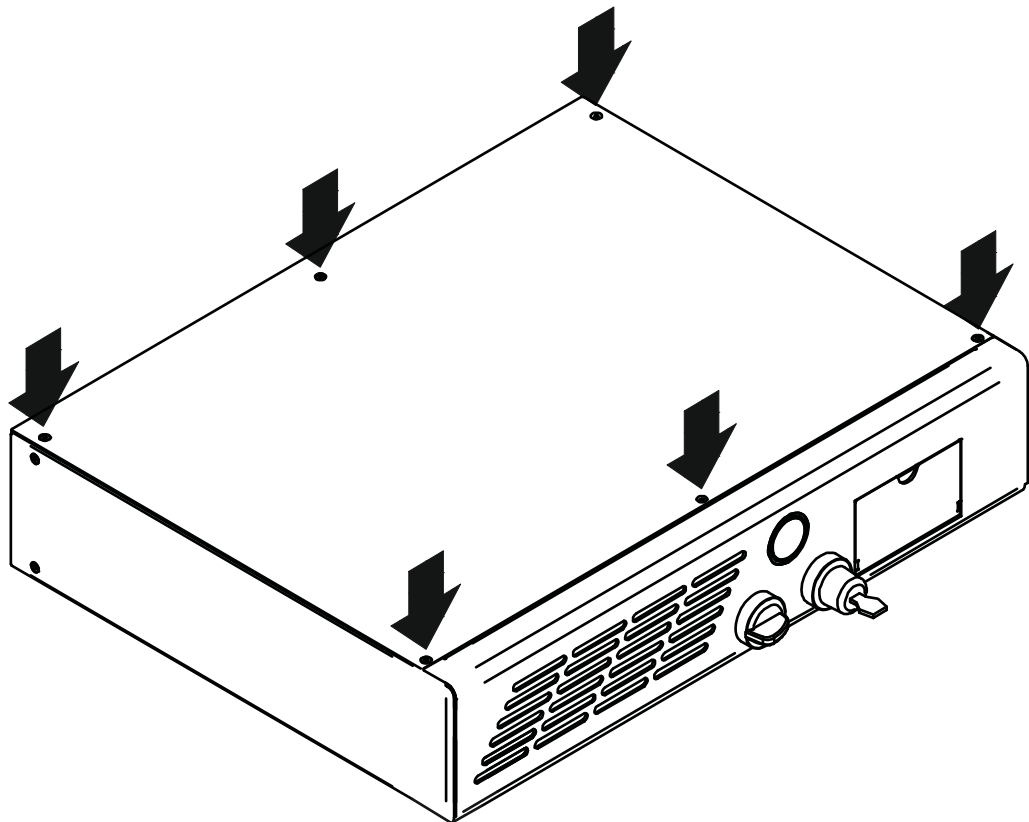

Figure 33: Closing rack

Connecting X1 - Command Box connector

The X1 - *Command Box connector* must always be inserted with properly signals provided in order to use the laser marker. The absence of such connector blocks the laser marker operations.



WARNING: If the Command Box Muting Device provided is connected, the laser marker enable is bypassed.

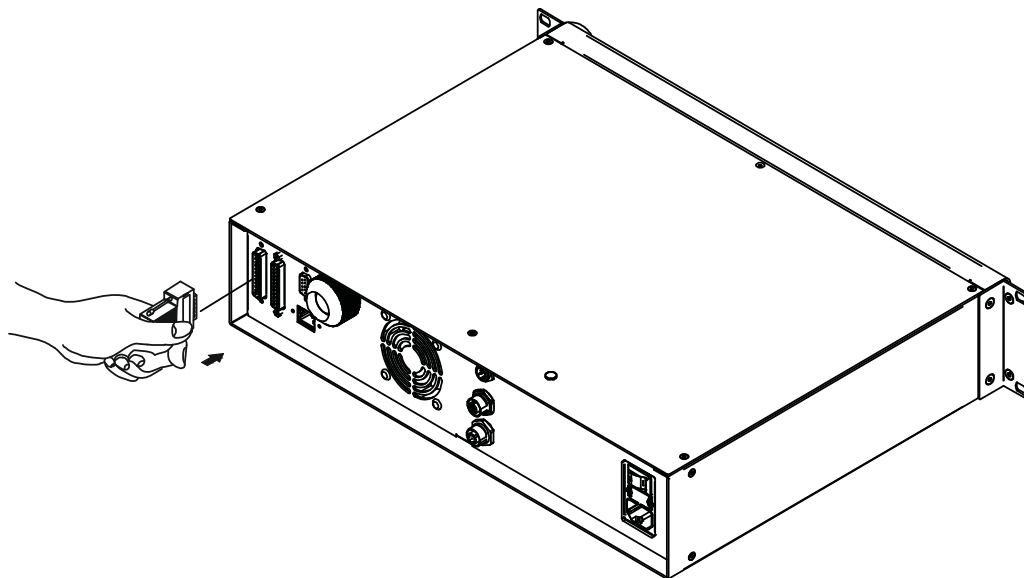

Figure 34: Connecting X1 - Command Box connector

Connecting Interlock connector

The *Interlock connector* must always be inserted with properly signals provided in order to use the laser marker. The absence of such connector blocks the laser emission.



WARNING: Do not use the Interlock Muting Device for external devices, since this will result in loss of the safety function of the machine to which this product is installed.

Do not use the Interlock Muting Device except for maintenance of this product.



WARNING: It is the customer's responsibility to provide a correct integration of the safety signals according to applicable regulations.

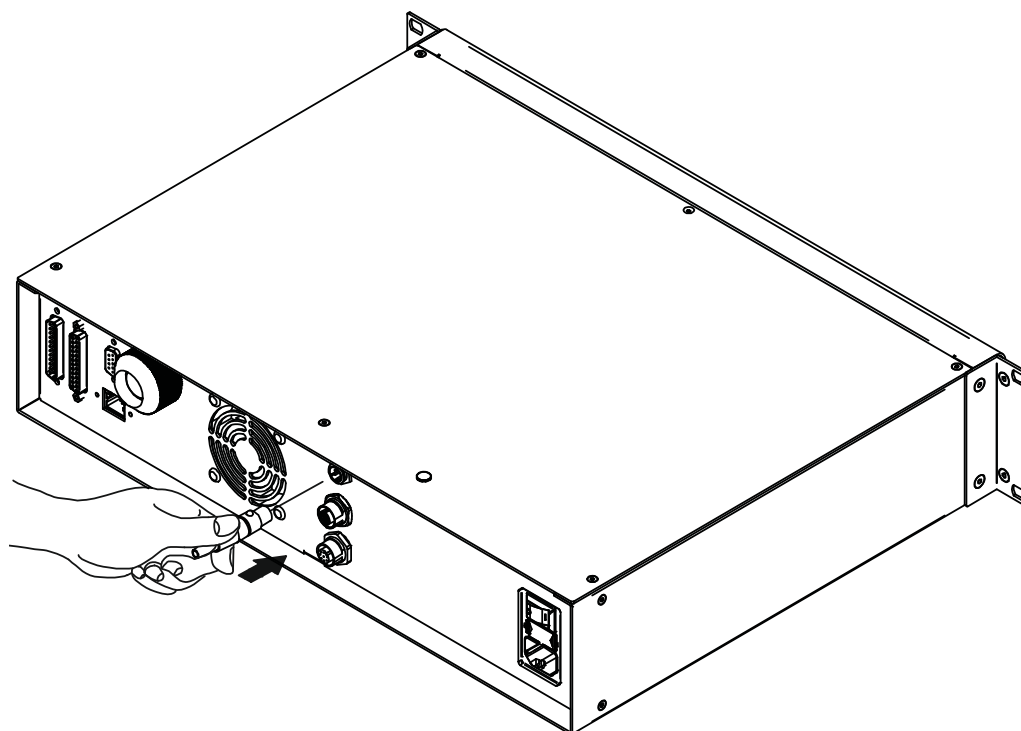

Figure 35: Connecting Interlock connector

Connecting Power Supply cable

Connect the Power Supply cable.

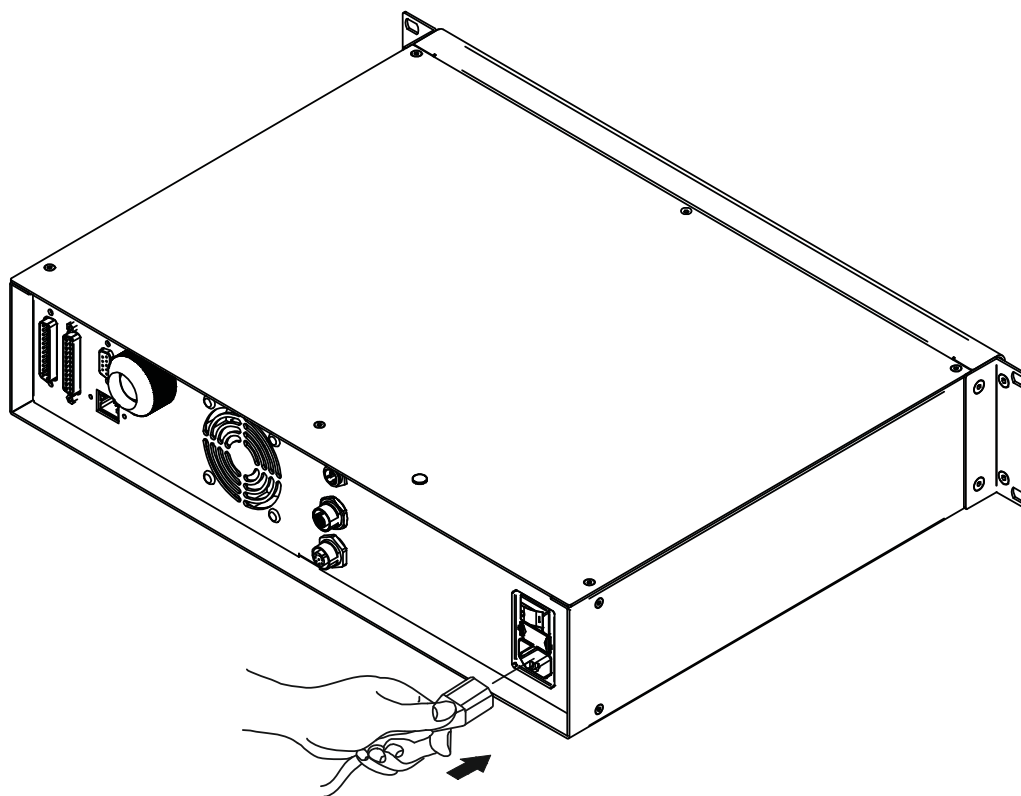

Figure 36: Connecting Power Supply cable

Local Mode Control connections

To use the laser marker in “Local Mode Control” it is necessary to install a mouse, keyboard and monitor. Connect the monitor and input devices to laser marker as shown below:

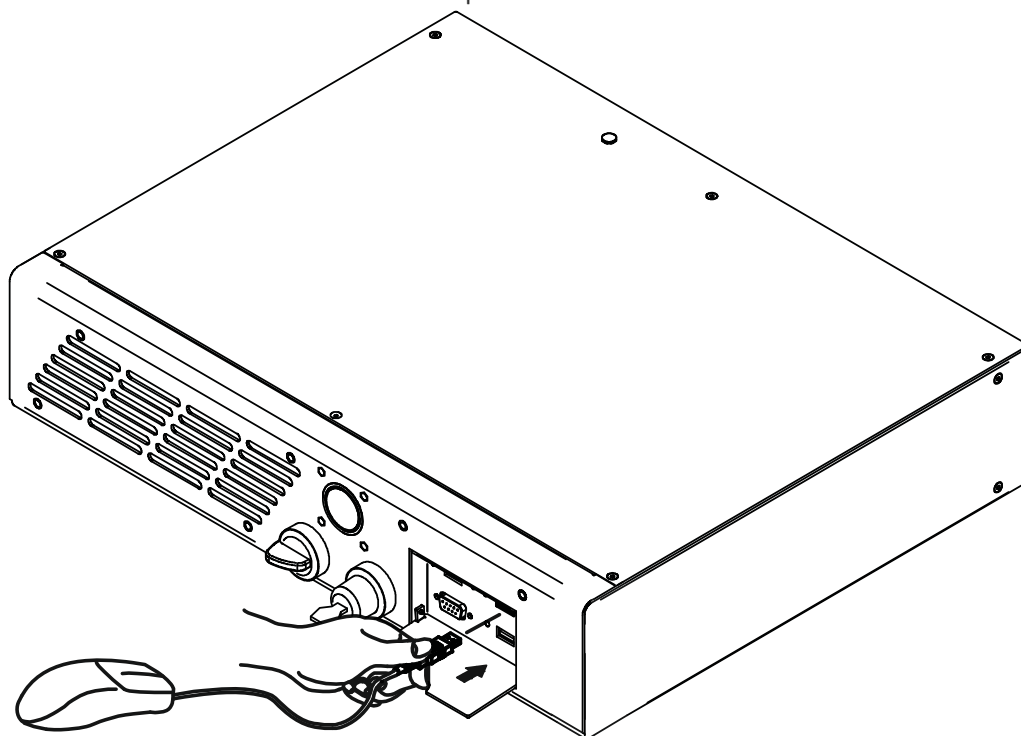

Figure 37: Connecting the mouse

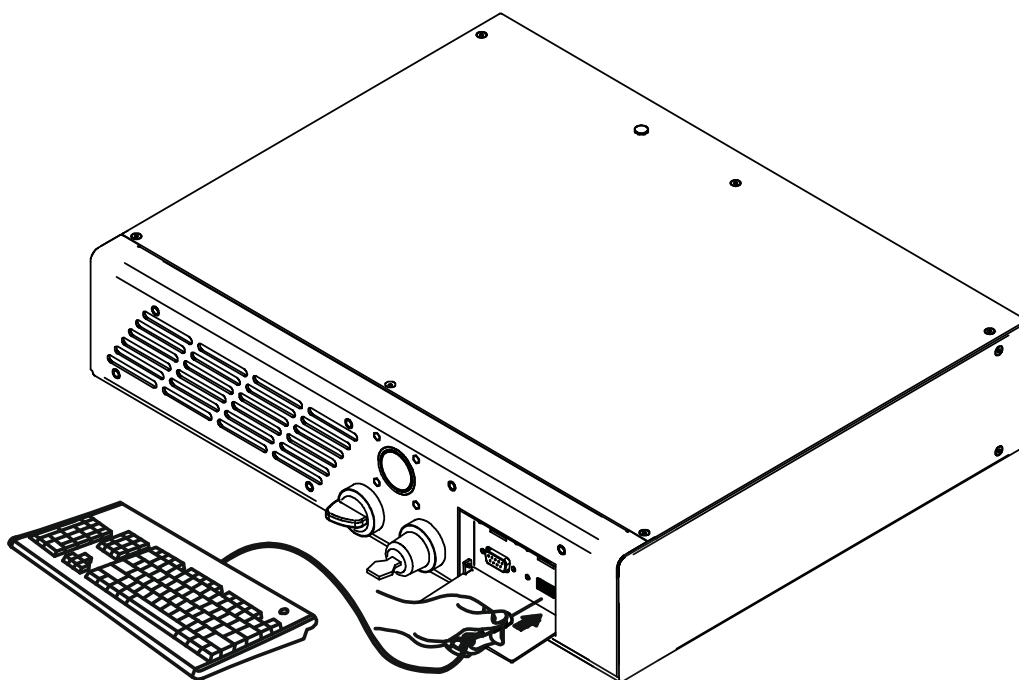

Figure 38: Connecting the keyboard

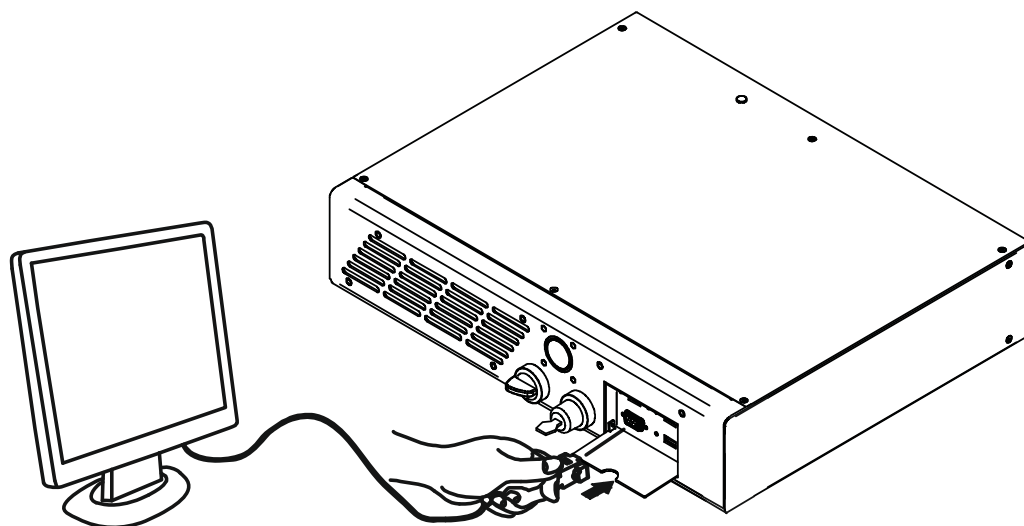

Figure 39: Connecting the monitor



NOTE: Minimum monitor resolution 800 x 600 (VGA standard).

Remote Mode Control connection

To use the laser marker in “Remote Mode Control” it is necessary to connect a network cable:

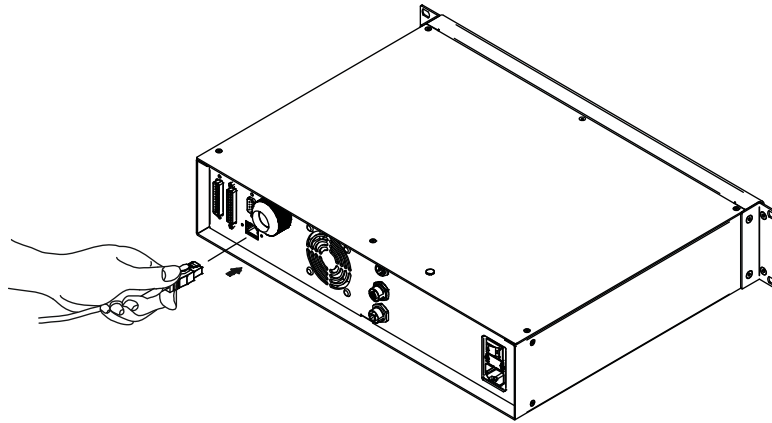

Figure 40: Connecting LAN port



NOTE: The LAN port is configured by default with a fixed IP Address and Subnet Mask:

- LAN Default IP address: 192.168.1.10

- Default Subnet Mask: 255.255.255.0

See “Change the LAN configuration and IP address” on page 63 in order to change LAN configuration.



NOTE: Ethernet TCP/IP 10, 100 Mbit.

F-THETA SCAN LENS PROTECTION CAP REMOVAL

Remove the F-Theta scan lens protection cap before marking operation:

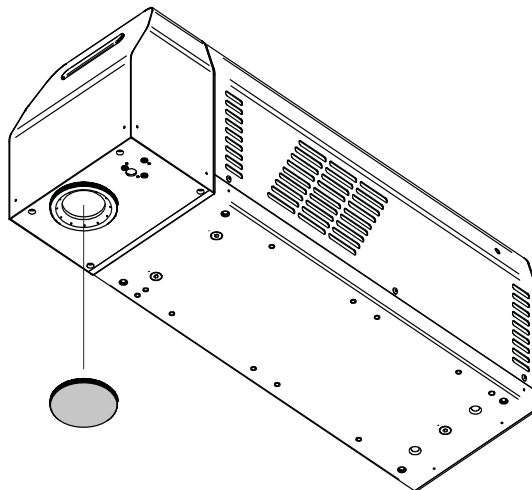

Figure 41: F-Theta scan lens protection cap removal



CAUTION: Marking with the lens protection cap in place could result in damage to the laser marker.

CHAPTER 5

USE AND OPERATION

Before turning on the laser marker, be sure that the laser marker is connected as previously described. Check the presence of:

- Voltage power supply connection
- Interlock connection
- X1 - Command Box connection



WARNING: Do not use the Interlock Muting Device for external devices, since this will result in loss of the safety function of the machine to which this product is installed.



Do not use the Interlock Muting Device except for maintenance on this product.



WARNING: It is the customer's responsibility to provide a correct integration of the safety signals according to applicable regulations.

TURNING ON SEQUENCE

Turn ON the main power supply switch in the back of the control rack.

STATE	X1 - COMMAND BOX INPUT STATE		STATUS LED
SYSTEM BOOTING UP	EXT_KEY EXT_ENABLE_A EXT_ENABLE_B	LOW	Control rack  Off
		LOW LOW	Resonator  Off

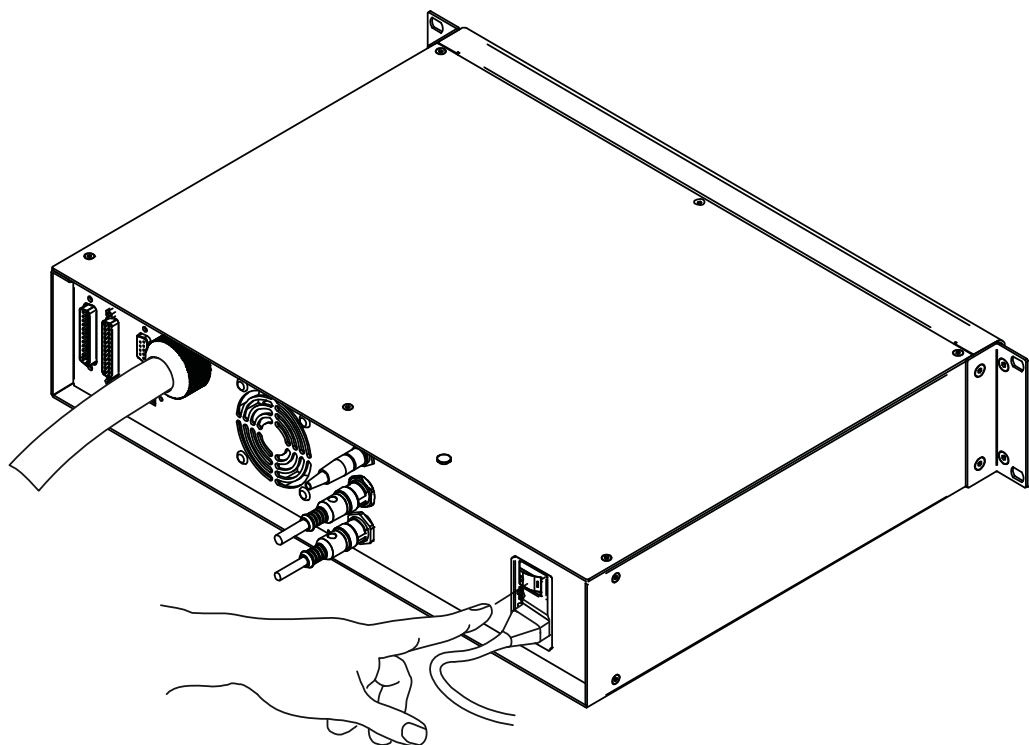

Figure 42: Power on the laser marker

If the laser marker is turned on cooling fans are running and the power supply LED light blue. It's possible to know if the laser marker is switched on checking the *EXT_12V auxiliary power supply* available on the *X1 - Command Box Connector*.

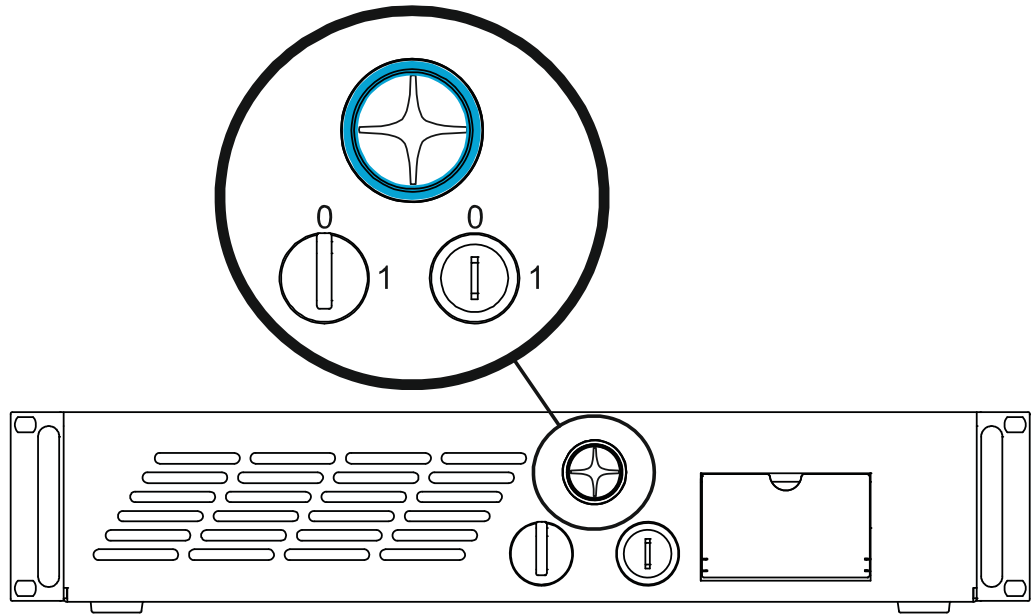

Figure 43: Power supply LED indicator

The control rack status LED will be blinking green. The LED bar on resonator is power off

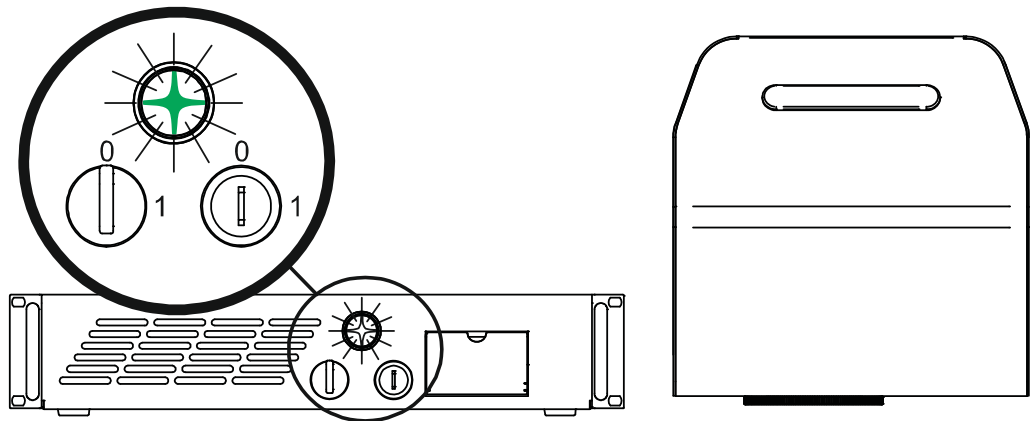





Figure 44: System Booting Up state

After booting up (~60 s) the laser marker goes into *WAIT FOR START* state:

STATE	X1 - COMMAND BOX INPUT STATE		STATUS LED
WAIT FOR START	EXT_KEY EXT_ENABLE_A EXT_ENABLE_B	LOW LOW LOW	Control rack
			 Steady Resonator  Off

Activate *EXT_KEY* signal on *X1 - Command Box connector*.

With *EXT_KEY* signal activated the status LED on the control rack turns orange, while the status LED bar on the resonator turns green and “*LASER_ACTIVE*” output signal is activated on *X1 - Command Box connector*:

STATE	X1 - COMMAND BOX INPUT STATE		STATUS LED
STANDBY SHUTTER CLOSED	EXT_KEY	HIGH	Control rack
		LOW	 Steady
	EXT_ENABLE_A	LOW	Resonator
	EXT_ENABLE_B	LOW	 Steady

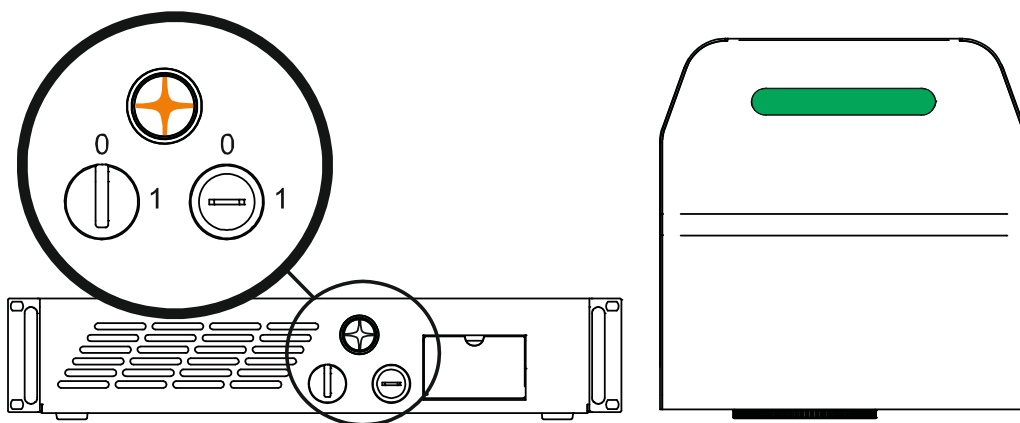



Figure 45: Standby Shutter Closed state

Activate *EXT_ENABLE_A* and *EXT_ENABLE_B* signals on the *X1 - Command Box connector*:

STATE	X1 - COMMAND BOX INPUT STATE		STATUS LED
READY	EXT_KEY	HIGH	Control rack
		HIGH	 Steady
	EXT_ENABLE_A	HIGH	Resonator
	EXT_ENABLE_B	HIGH	 Steady

The laser marker is ready to mark. The status LED on the control rack turns red, while the status LED bar on the resonator turns orange. “*SHUTTER_OPEN*” output signal is activated on *X1 - Command Box connector*.



WARNING: During this status, the Shutter is opened and it is possible to have LASER beam output.

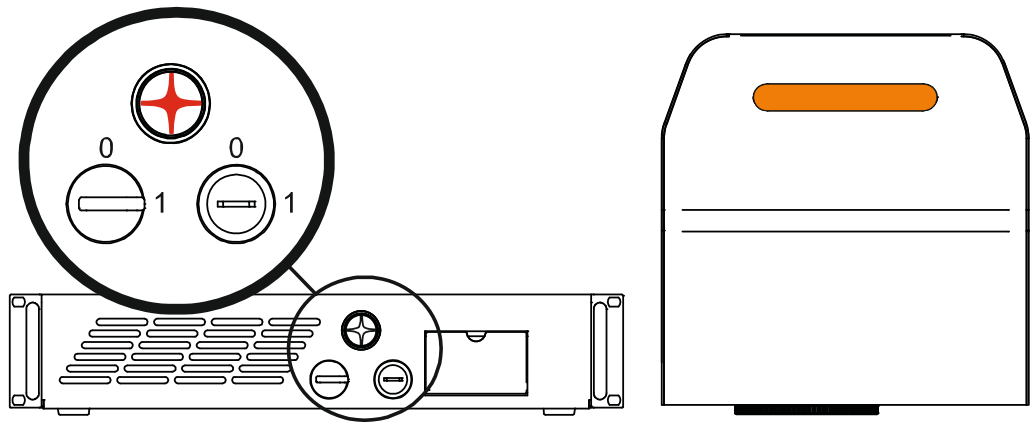



Figure 46: Ready state

During laser emission, all status LED are red.

STATE	X1 - COMMAND BOX INPUT STATE		STATUS LED
BUSY	EXT_KEY EXT_ENABLE_A EXT_ENABLE_B	HIGH HIGH HIGH	Control rack  Steady
			Resonator  Steady

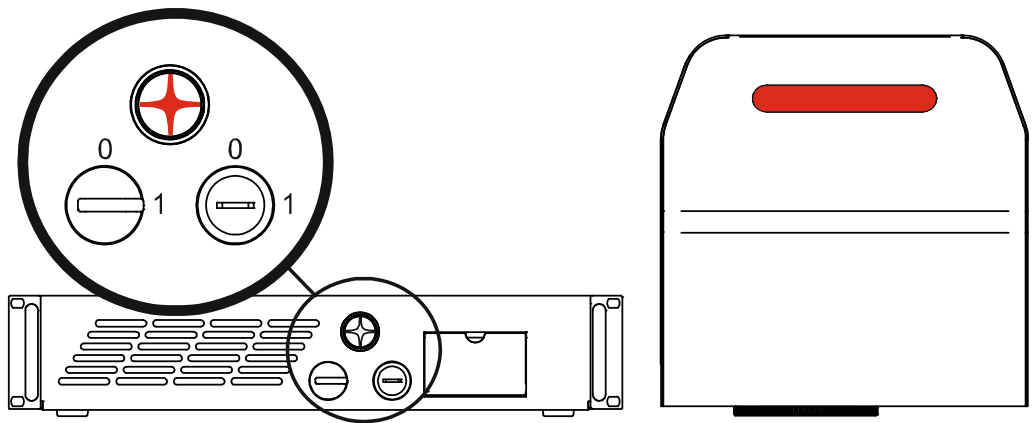

Figure 47: Busy state

CHAPTER 6

CUSTOMIZE THE LASER MARKER SOFTWARE

SYSTEM PROTECTION

The System Protection enhances the security of the system against disk corruption that might be caused by unexpected system shutdowns or malware attacks and protects the **C:\ drive** from unwanted changes.

When the System Protection is enabled, any change or deletion on the C:\ drive will be restored after system reboot, otherwise when the System Protection is disabled any modification will be stored on the disk and it will persist after reboot.

System Protection Tool

The System Protection tool shows the status of the System Protection and is visible on the tray-bar icon in the lower- right corner of the screen.

A notification popup message that shows the status of System Protection is still visible on the screen for a few seconds after system startup.

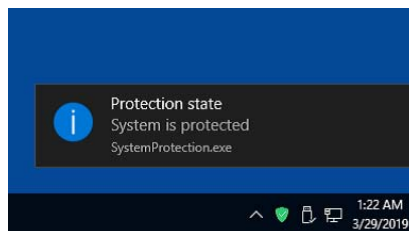

The tray-bar icon color represents the protection state:

- **Red:** the system protection is **disabled**
- **Green:** the system protection is **enabled**
- **Yellow:** the system **must be rebooted** to apply the new settings

How to use the System Protection tool

The System Protection tool GUI can be opened:

- By clicking on the notification popup
- By right-clicking the tray-bar icon then, “Configure”
- Double-clicking the tray-bar icon
- From *Start Menu\Datalogic\System Protection*

Enable the system protection



NOTE: When the System Protection is enabled any change or deletion on the C:\ drive will be restored after system reboot.

- Open the System Protection tool GUI
- Click the **ENABLE** button

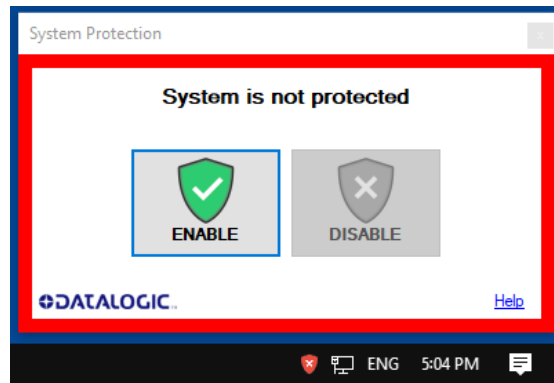

- A message advise the User to confirm the new setting. Press **YES** to enable System Protection

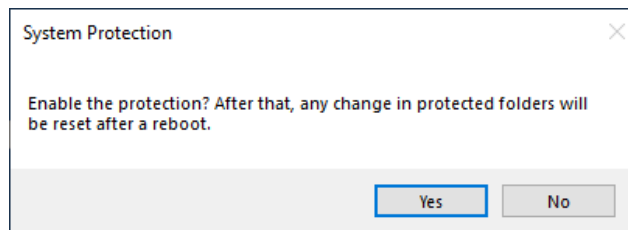

- A message advise the User that the system will be rebooted. Press **YES** to continue

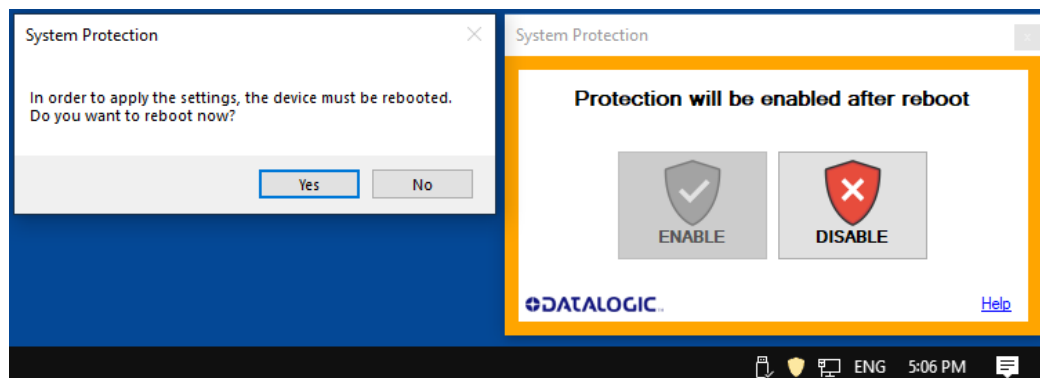

- Wait for system reboot



CAUTION: DO NOT turn OFF or UNPLUG the system while Windows® is shutting down.

- Check if the Tray-bar icon color is **GREEN** (protection enabled)

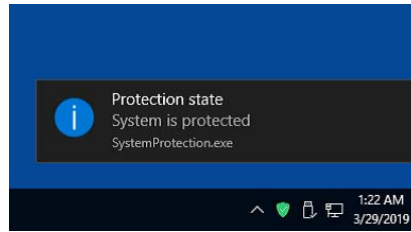

Disable the system protection



CAUTION: When the System Protection is disabled the system is not protected against disk corruption or malware attacks. Disable the protection only for the time necessary to make disk changes.

- Open the System Protection tool GUI
- Click the **DISABLE** button

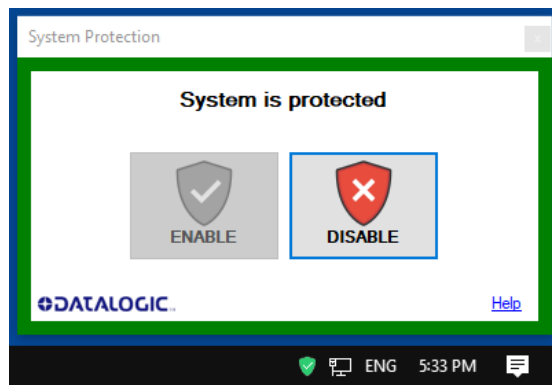

- A message advise the User to confirm the new setting. Press **YES** to disable System Protection

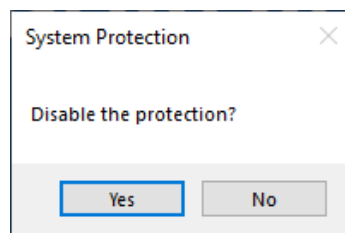

- A message advise the User that the system will be rebooted. Press **YES** to continue

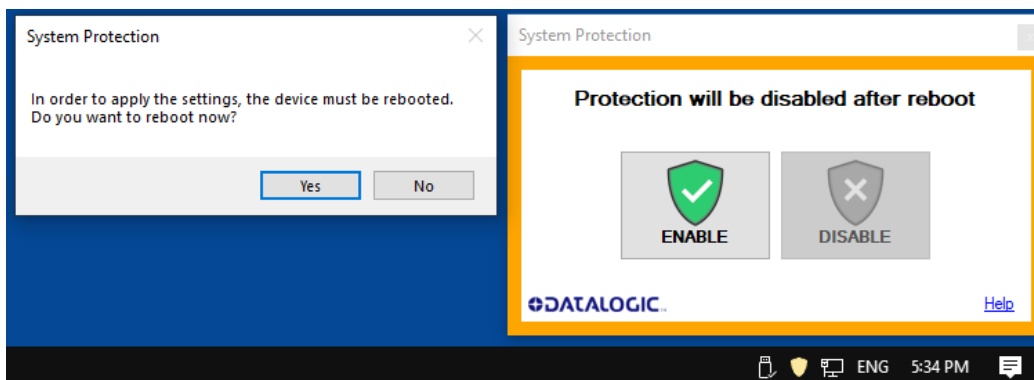

- Wait for system reboot



CAUTION: DO NOT turn OFF or UNPLUG the system while Windows® is shutting down.

- Check if the Tray-bar icon color is **RED** (protection disabled)

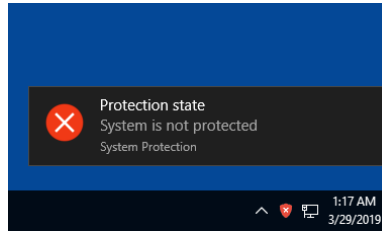

CHANGE O.S. LANGUAGE AND KEYBOARD LAYOUT

The laser marker allows you to customize the operating system changing the language used in menus, dialogs and languages you can use to enter text and keyboard layout.

The following languages are pre-installed in the system: Chinese (PRC), Chinese (Taiwan), English (United States), French (France), German (Germany), Italian (Italy), Japanese (Japan), Korean (Korea), Spanish (Spain).



NOTE: In order to perform this setting it is necessary to connect mouse, keyboard and monitor to the laser marker (see “Local Mode Control connections” on page 48).

1. Disable system protection (see “Disable the system protection” on page 58)



CAUTION: When the System Protection is disabled the system is not protected against disk corruption or malware attacks. Disable the protection only for the time necessary to make disk changes.

2. Wait for the operating system to **restart**
3. Check that the System Protection is **disabled** (red icon):

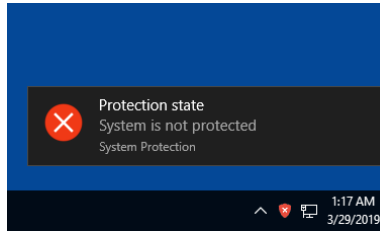

4. Click the **Search icon** and type “**language**”
5. Click on **Language settings**

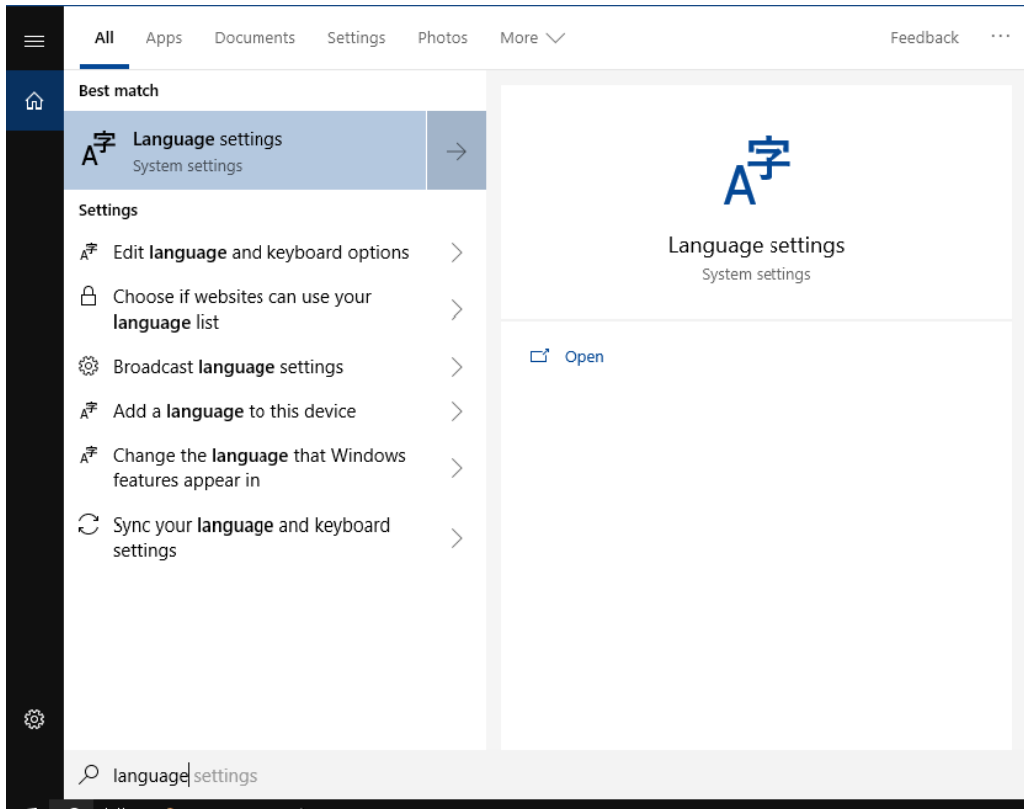

6. Select the Windows display language:

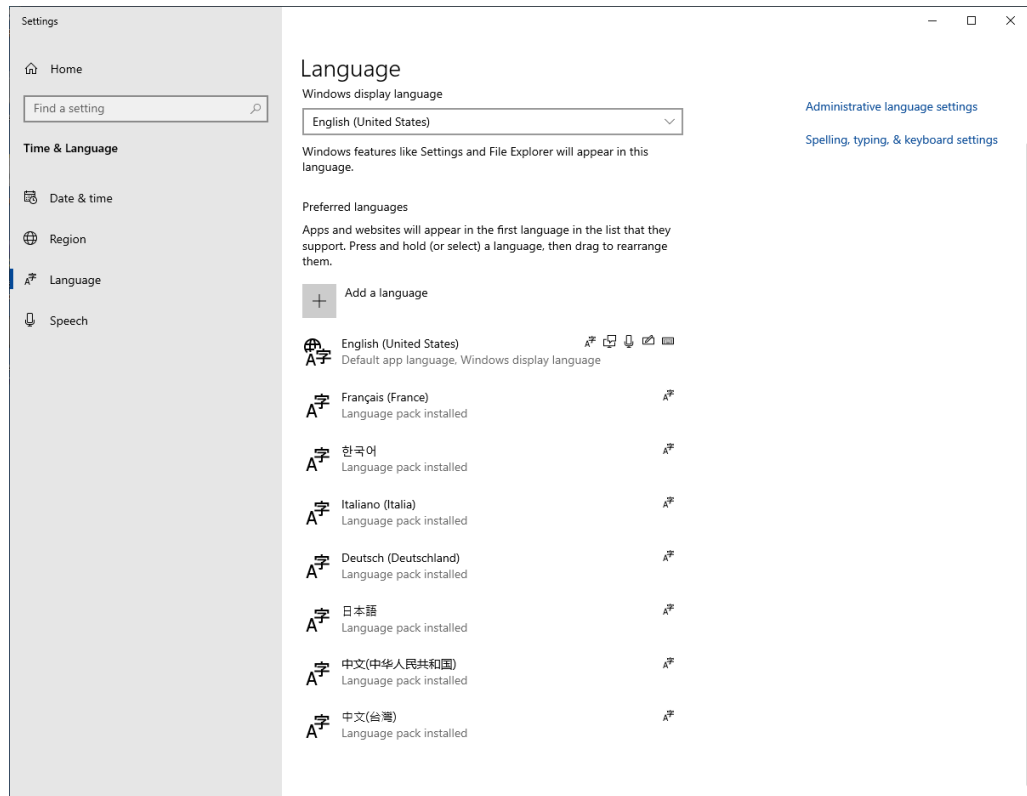
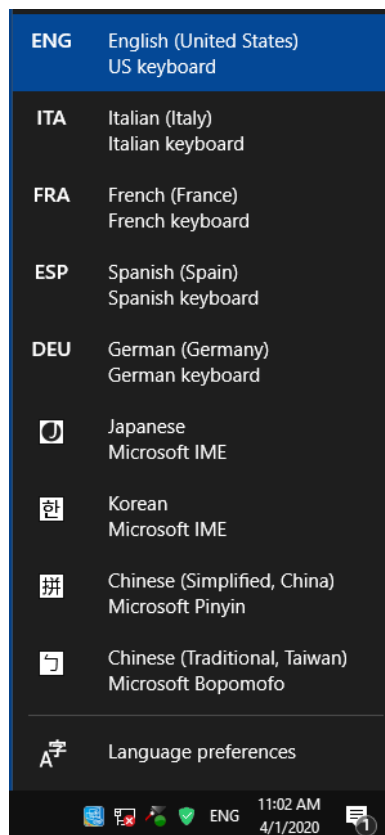
7. Click on the **Input Indicator** icon in the taskbar8. Select the **keyboard layout** from the list:

9. Close all the open windows

10. Enable system protection (see “Enable the system protection” on page 57)



CAUTION: When the System Protection is disabled the system is not protected against disk corruption or malware attacks.

11. Wait for the operating system to **restart**
12. Check that the System protection is **enabled** (green icon):

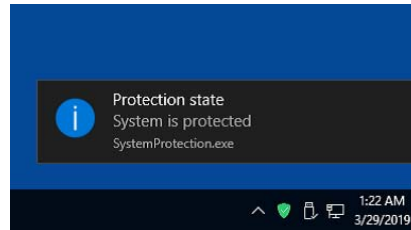

CHANGE THE LAN CONFIGURATION AND IP ADDRESS

The operating system allows you to change the LAN configuration and IP address.



NOTE: In order to perform this setting it is necessary to connect mouse, keyboard and monitor to the laser marker (see “Local Mode Control connections” on page 48).

1. Disable system protection (see “Disable the system protection” on page 58)



CAUTION: When the System Protection is disabled the system is not protected against disk corruption or malware attacks. Disable the protection only for the time necessary to make disk changes.

2. Wait for the operating system to **restart**
3. Check that the System protection is **disabled** (red icon):

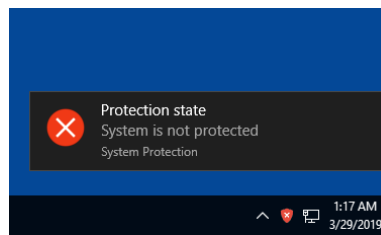

4. Click the **Search icon** and type “Ethernet”
5. Click on **Ethernet settings**

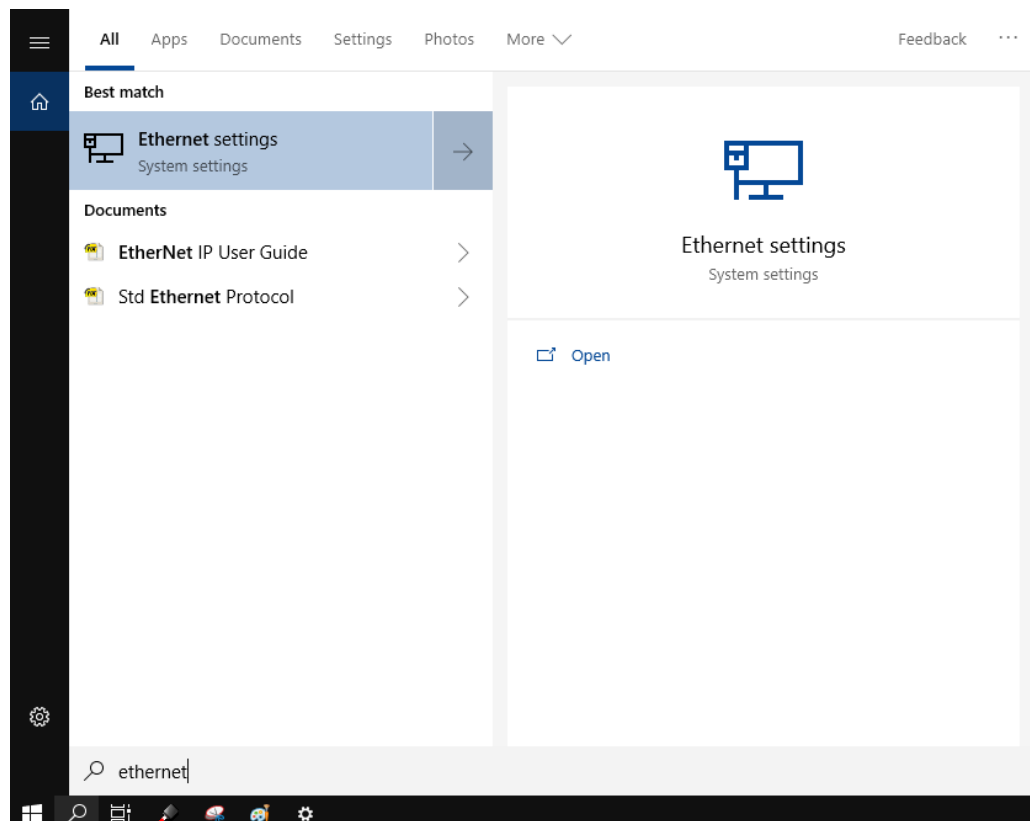

6. Click on **Change adapter options**

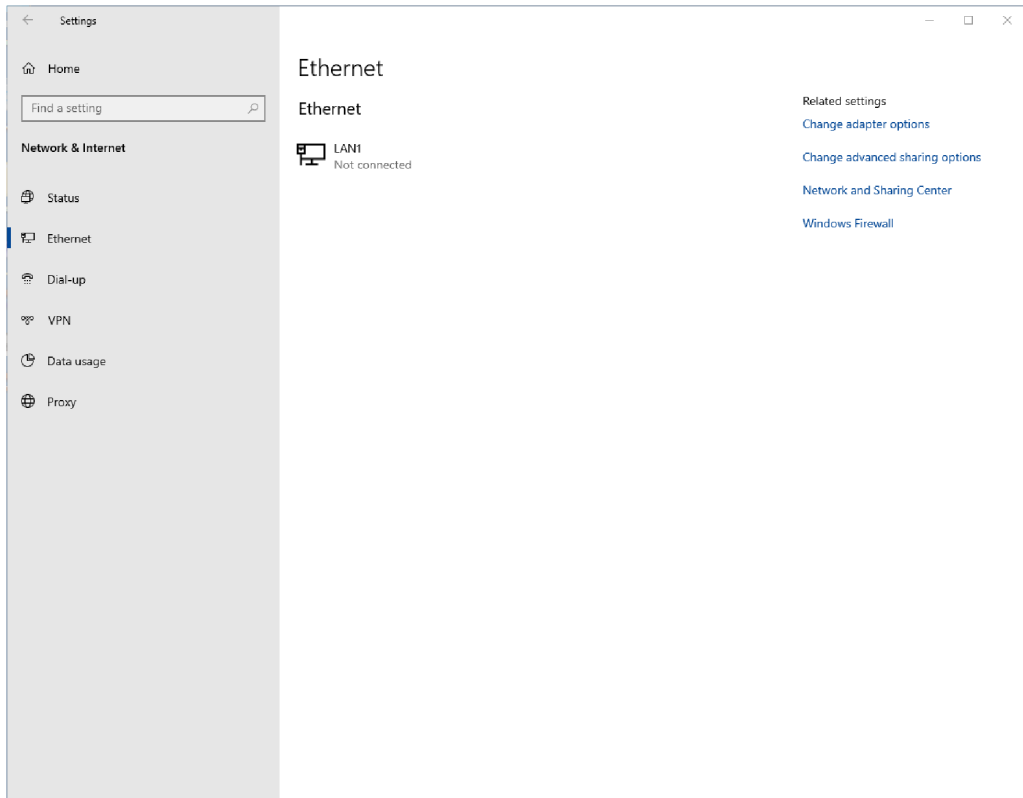

7. In the Network Connections window double click on the desired Network icon:

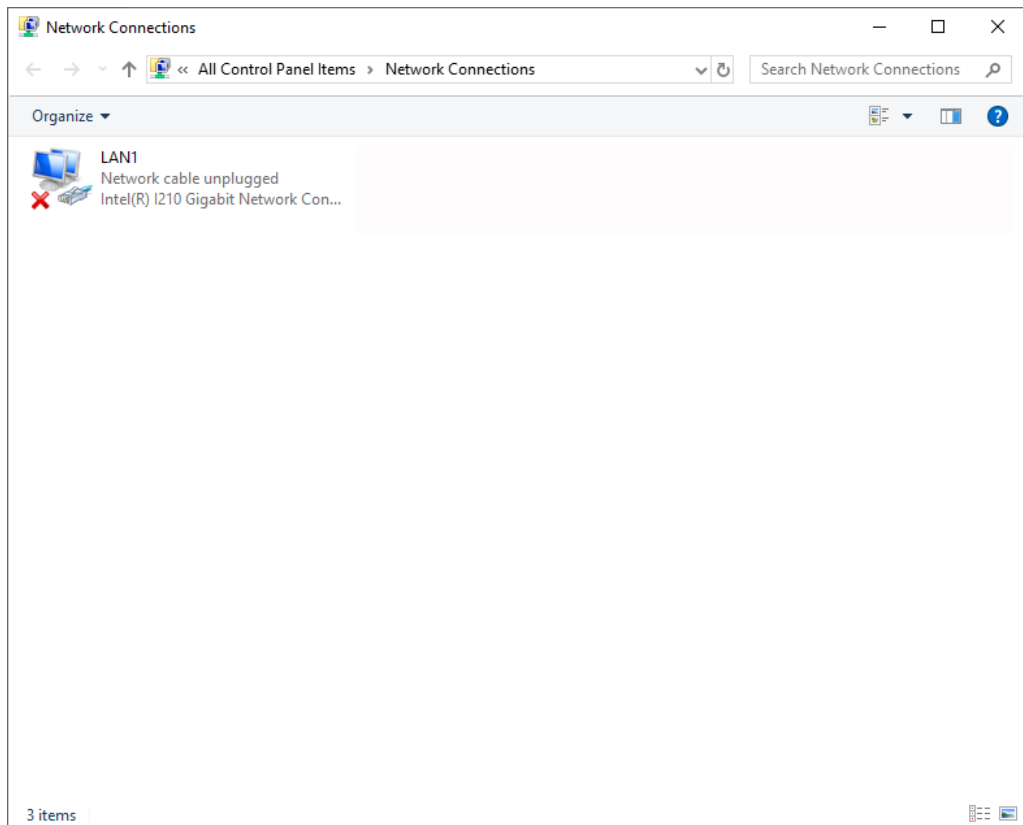

- In the Network Properties window double click on **Internet Protocol Version 4 (TCP/IPv4)** and edit the IP address and/or subnet mask.

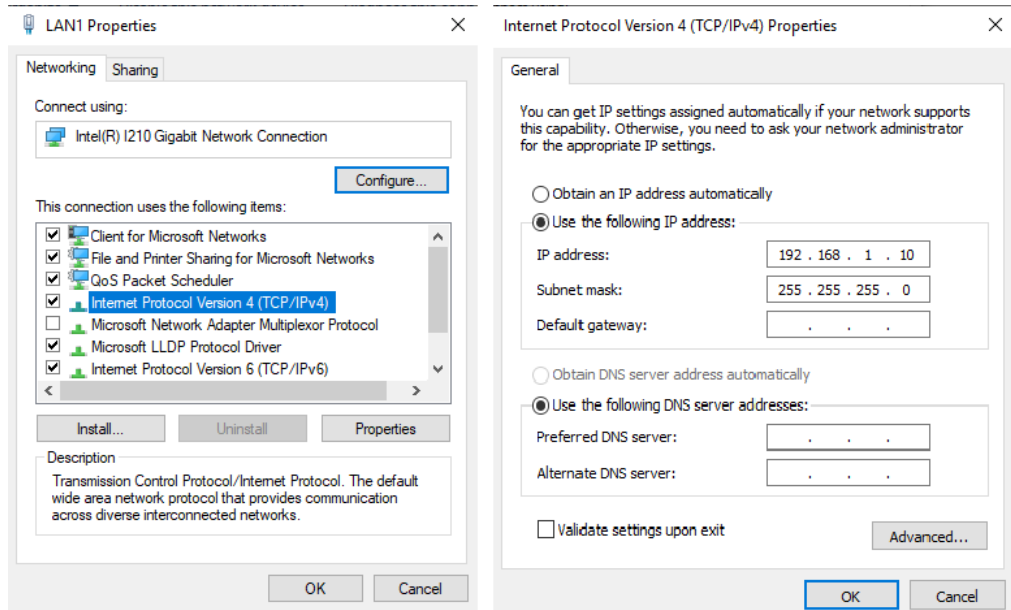

- Close all the open windows
- Enable system protection (see “Enable the system protection” on page 57)



CAUTION: When the System Protection is disabled the system is not protected against disk corruption or malware attacks.

- Wait for the operating system to **restart**
- Check that the System protection is **enabled** (green icon):

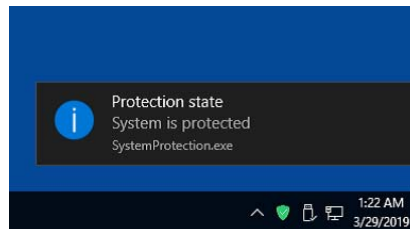

CHANGE THE VIDEO SETTING

The operating system allows you to change the Video setting.



NOTE: In order to perform this setting it is necessary to connect mouse, keyboard and monitor to the laser marker (see “Local Mode Control connections” on page 48).

1. Disable system protection (see “Disable the system protection” on page 58)



CAUTION: When the System Protection is disabled the system is not protected against disk corruption or malware attacks. Disable the protection only for the time necessary to make disk changes.

2. Wait for the operating system to **restart**
3. Check that the System protection is **disabled** (red icon):

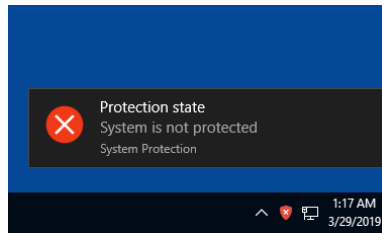

4. Click the **Search icon** and type “display”
5. Click on **Display settings**

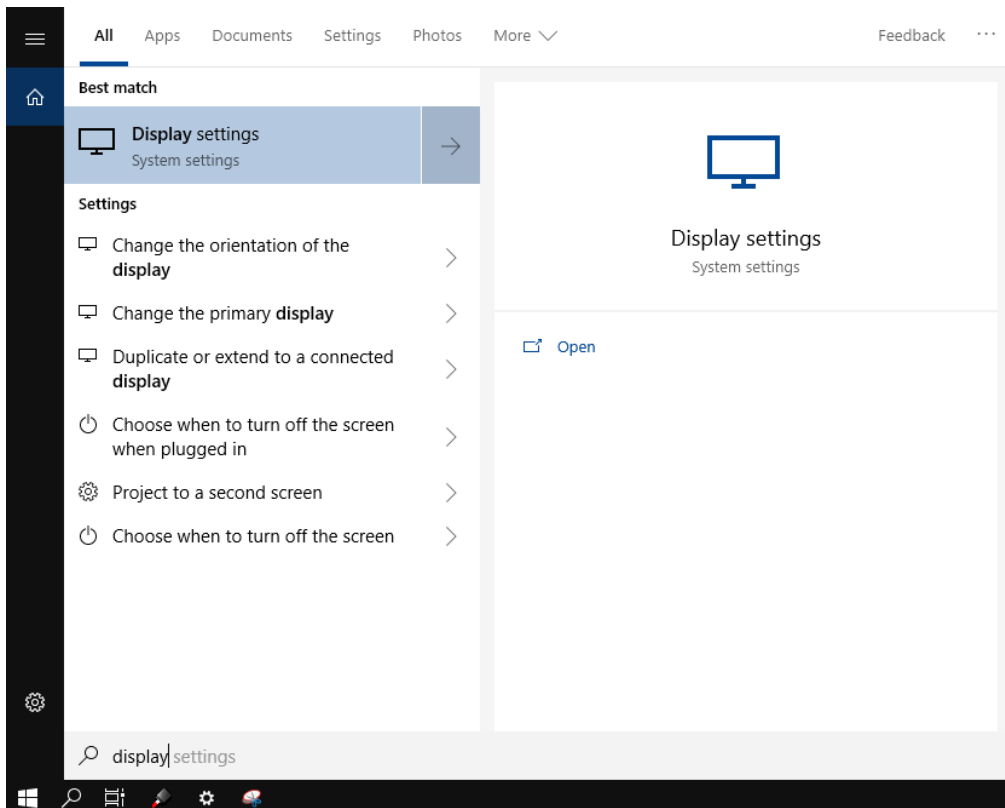

6. Change the Display settings

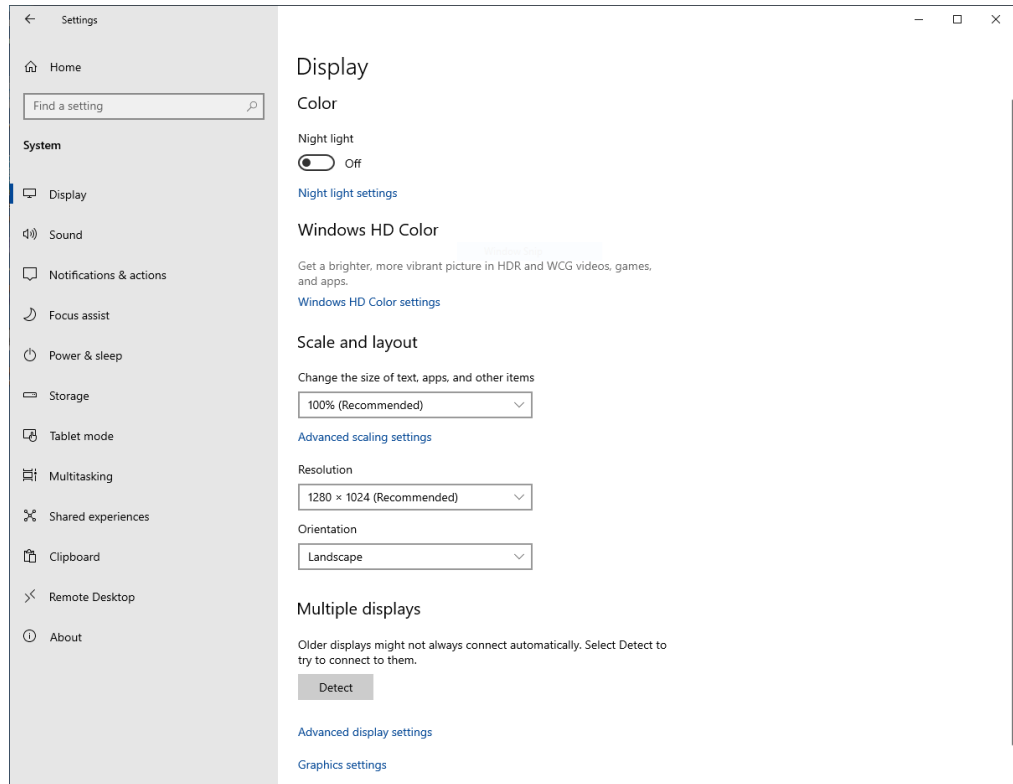

7. Close all the open windows

8. Enable system protection (see “Enable the system protection” on page 57)



CAUTION: When the System Protection is disabled the system is not protected against disk corruption or malware attacks.

9. Wait for the operating system to restart

10. Check that the System protection is **enabled** (green icon):

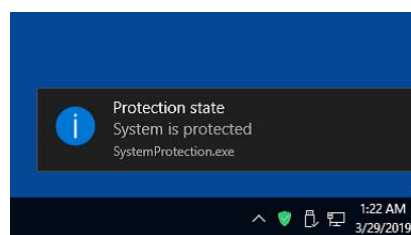

REMOTE DESKTOP CONNECTION

To connect the laser marker to a remote Windows® based computer, follow these steps:

1. Turn on the laser marker
2. Make sure that both laser marker and remote computer are connected to the LAN
3. Click **Start > All Programs > Accessories**, and then click **Remote Desktop Connection**
4. Click **Options**
5. In the Computer list, type the host name or the IP address of the computer to which you want to connect
6. Type the user name, password, and domain (if applicable) of an account to which you have allowed remote access into the corresponding boxes, and then click **Connect**

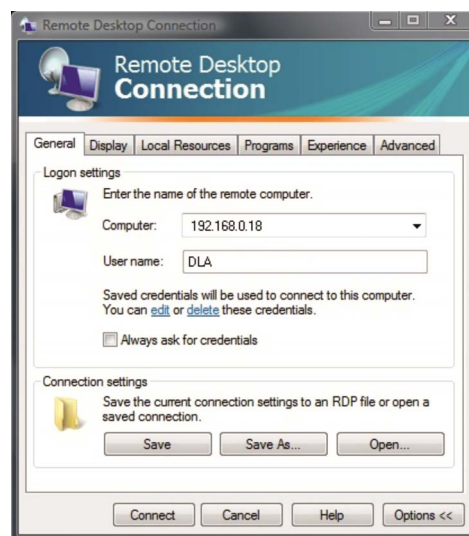

7. In the **Log On to Windows®** dialog box that appears, type the password of the account with remote access privileges into the Password box:

User name: **DLA**

Password: **dla**



8. In the **Log on to** list, if applicable, select the domain or remote computer that you want, and then click **OK**.
The remote desktop is displayed in a window on the desktop. The remote computer is locked during this session
9. To disconnect the session, click the **Close** button in the session window, and then click **OK** when you are prompted to disconnect the Windows® session.

CHAPTER 7

ACCESSORIES

The accessories listed here below are described for information purposes only, and are not necessarily included in the packaging. The minimum contents of the packaging include the main hardware, cables and keys. For additional information, please see “Contents of the packaging” on page 10.

CONTROL BOX

This accessory is used to control the laser marker through the Control Box interface.

The Control Box allows to perform the following functions:

- Changing laser marker state
- Starting and Stopping the marking process
- Showing the marking process state
- Showing the system error state

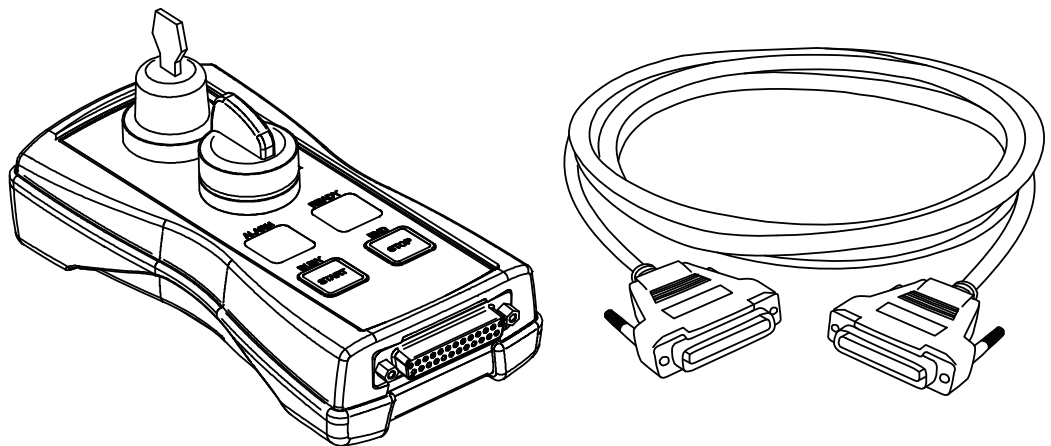

Figure 48: Control Box (ordering no: 985330031)



NOTE: See "X1 - Command Box (Laser Control)" on page 26 for detailed control signal description.

REMOTE START FOOT SWITCH

This accessory is used to provide the *START_MARKING* signal to the laser marker when the pedal is pressed by the operator.

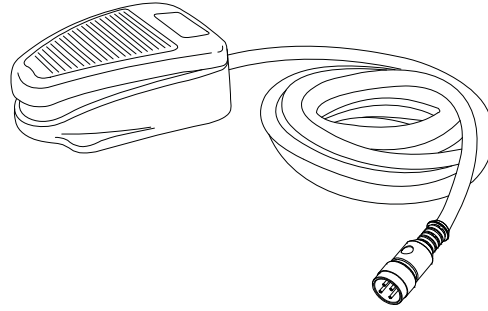

Figure 49: Remote Start Foot Switch (ordering no: 985350035)



NOTE: Refer to Remote Start Foot Switch instruction manual for more information.

I/O INTERFACE

Dedicated to on-site quick and easy termination, PLC interfacing, System Test, I/O troubleshooting, etc. The DB25 Pass-through Command Box connector allows the integrator to use the interface as a I/O test tool on previously installed products.

- I/O Monitoring LED
- Easy assembly thanks to screw down termination
- Dry contact outputs
- Dry contact inputs
- DIN rail mounting enclosure

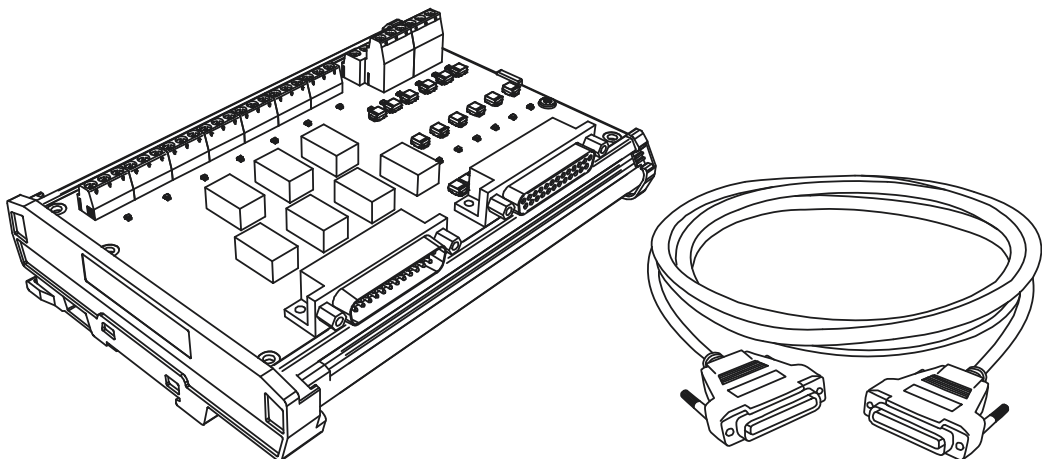

Figure 50: I/O interface (ordering no: 985330032)



NOTE: Refer to I/O Interface instruction manual for more information.

DB25-TO-FREE LEADS CABLE

This accessory allows an easier integration of the laser marker: the Command Box connector signals are all available on the free leads side of the cable, labeled with cable tags.

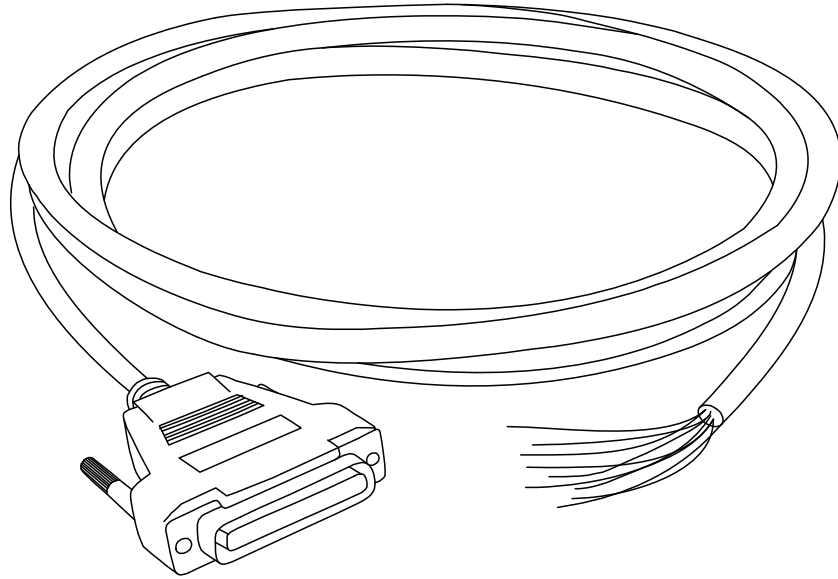

Figure 51: DB25-to-free leads cable (ordering no. 985350032)

FUME EXTRACTOR

This accessory is suitable for collecting and filtering dry and non combustible types of dust contained in non explosive air mixtures produced during laser marking.

MODEL	ELECTRICAL DATA	HOSE / NOZZLE
985340038 - FUME EXTRACTOR BASIC 230VAC	230 VAC, 1 phase, @ 50 Hz (EU)	50-50 mm hose, length 4 m. 50 mm nozzle assembly
985340040 - FUME EXTRACTOR BASIC 115VAC	115 VAC, 1 phase, @ 60 Hz (US)	50-50 mm hose, length 4 m. 50 mm nozzle assembly
985340039 - FUME EXTRACTOR PRO 90-257VAC	90 - 257 VAC, 1 phase, @ 50-60 Hz	75-50 mm hose, length 4 m. 50 mm nozzle assembly

CHAPTER 8

TECHNICAL SUPPORT

SEALS

The laser marker has seals in some areas. The seals must not be broken or removed for any reason. The sealed parts may be opened only and exclusively by Datalogic. Breaking these seals voids the warranty on the entire laser marker.



CAUTION: If customer breaks or removes the seals placed by Datalogic on the laser marker the warranty will immediately become “null and void”.



CAUTION: Datalogic shall not be held liable for any non-conforming use of the laser marker.

It is forbidden to operate the laser marker before the machine where it is integrated has been declared in conformance with applicable statutory Directives.



CAUTION: Only Datalogic authorized personnel, who have been trained and instructed on the electrical and optical risks, is allowed to access the internal parts of the laser marker.

Datalogic shall not be held liable for any damage caused by inadequate work from non-authorized personnel.

MAINTENANCE

The ordinary maintenance program of the laser marker includes only simple operations. Some operations consist in a mere “check” of the operating condition.

The maintenance activities must be done in compliance with the legal directives regarding the safety rules during these operations.

The following parts/functions have to be controlled periodically:

COMPONENT	TYPE OPERATION	INTERVALS
F-Theta Scan Lens	Check / Clean	Weekly: wipe gently with a dry cloth (or soaked in high purity isopropyl alcohol) or clean it with dry air blowing
Fan and heat exchanger unit	Check	Every 6 months (according to the place and frequency of use)



CAUTION: Disconnect AC power cable before starting any maintenance operations.

F-Theta scan lens cleaning procedure

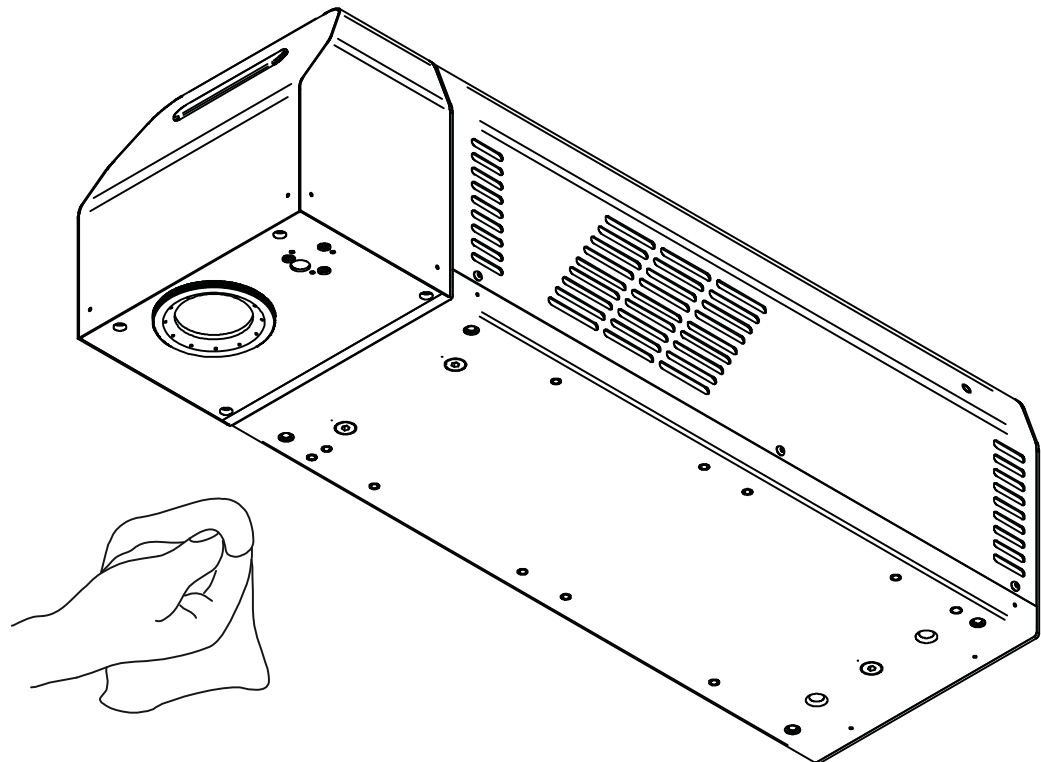

Figure 52: Cleaning F-Theta scan lens

TROUBLESHOOTING

If a problem occurs during operation, first check the following troubleshooting. If you cannot fix the problem, contact Datalogic customer service (see “Technical Support” on page vi).

List of warning and error states

STATUS LED	DESCRIPTION		ACTION	OUTPUT STATE COMMAND BOX CONNECTOR	
Blinking ORANGE (2 Hz)	Warning invalid start sequence	Incorrect turning-on sequence	Repeat the “Turning On sequence” on page 52	SYSTEM_ALARM LASER_ACTIVE SHUTTER_OPEN	OFF OFF OFF
Blinking RED (2 Hz) at Power ON	System Error	Interlock error	- Check interlock connector signals (see “Interlock” on page 24) - Check Interlock connector presence	SYSTEM_ALARM LASER_ACTIVE SHUTTER_OPEN	ON OFF OFF
		Connector Presence error	- Check X1.10 (<i>CONNECTOR_PRESENCE</i>) input signal of the X1 - Command Box connector (see “X1 - Command Box (Laser Control)” on page 26): HIGH level: normal operation; LOW level or disconnected: system error - Check if X1 - Command Box connector is present		
Blinking RED (2 Hz) after KEY activation	System Error	Resonator Error	- Check that the system is working in the correct temperature range - Contact Datalogic technical support	SYSTEM_ALARM LASER_ACTIVE SHUTTER_OPEN	ON OFF OFF
		Shutter Error	Contact Datalogic technical support		

List of problems related to laser marker states

PROBLEM DESCRIPTION	STATUS LED BAR		ACTION
Laser marker never exit BOOTING UP state	Turned OFF	Lighter™ Suite marking SW corrupted C:\ or D:\ drive corrupted	Restore the laser marker (see “How to recover the laser marker” on page 103)
Laser marker never goes to STANDBY SHUTTER CLOSED state	Turned OFF	EXT_KEY contact is LOW level or disconnected	Check X1.12 (<i>EXT_KEY</i>) input signal on the X1 - Command Box connector is set to HIGH level (see “X1 - Command Box (Laser Control)” on page 26)
Laser marker never goes to READY state	Steady GREEN	EXT_ENABLE_A and/or EXT_ENABLE_B contact are LOW level or disconnected	Check X1.8 (<i>EXT_ENABLE_A</i>) and X1.2 (<i>EXT_ENABLE_B</i>) input signals on the X1 - Command Box connector are set to HIGH level (see “X1 - Command Box (Laser Control)” on page 26)

List of most common problems

PROBLEM DESCRIPTION	POSSIBLE CAUSE	ACTION
Laser marker doesn't turn ON	Power supply cable disconnected	Check the POWER SUPPLY CABLE connection to the power grid
	SWITCH of power supply set to OFF	Check that the POWER SUPPLY switch is set to ON
	FUSES damaged	Check that FUSES of power supply are not damaged
Impossible to control the marking process using the Command Box control signals	Incorrect integration	Check that the Command Box control signals are compatible with the external devices used for integration
Bad marking result	F-Theta scan lens is dirty	Clean the F-Theta scan lens. See “F-Theta scan lens cleaning procedure” on page 73
	Incorrect focus distance	Check that the material to be marked is placed at the right working distance. See “Marking Area Specification” on page 22
	Incorrect laser parameters	Check that the laser parameters set in the layout are appropriate for the material to be marked. Contact Datalogic Technical Support
Laser marker doesn't engrave	Incorrect laser marker state	Check the laser marker state is set to READY
	F-Theta lens protection not removed	Check that the F-Theta scan lens protection has been removed
	The optical path is obstructed	Check that the optical path is free
Laser marker doesn't start to engrave using external START_MARKING signal on the Command Box connector	STOP_MARKING signal is active	Check that the X1.13 (<i>STOP_MARKING</i>) signal on the X1 - Command Box connector is not set to HIGH level
	START_MARKING signal incorrect timing	- Check the X1.11 (<i>START_MARKING</i>) signal on the X1 - Command Box connector (see “X1 - Command Box (Laser Control)” on page 26). HIGH level pulsed signal start the marking process (refers to Lighter™ user's manual “Setting I/O parameters” paragraph to set the signal properties) - Use Lighter™ System Test to check external <i>START_MARKING</i> and <i>STOP_MARKING</i> signals
	Lighter™ is not set in AUTO MODE / WORK MODE	Check that Laser Engine is set in AUTO MODE or that Laser Editor is set in WORK MODE

PROBLEM DESCRIPTION	POSSIBLE CAUSE	ACTION
Laser marker doesn't start to engrave using an external photocell	STOP_MARKING signal is active	Check that the X1.13 (STOP_MARKING) signal on the X1 - Command Box connector is not set to HIGH level
	Incorrect photocell type or incorrect connection	Check that the photocell is compatible with the laser marker (see "Photocell" on page 29). HIGH level pulsed signal start the marking process (refers to Lighter™ user's manual "Setting I/O parameters" paragraph to set the signal properties)
	Lighter™ is not set in AUTO MODE / WORK MODE	Check that Laser Engine is set in AUTO MODE or that Laser Editor is set in WORK MODE
Laser marker doesn't work in Marking On Fly mode	MOF is not enabled or not configured	- Use the Laser Engine MOF wizard to setup the laser marker (refers to Lighter™ User's Manual) - Check that the MOF MODE is enabled (refers to Lighter™ User's Manual)
	Laser Engine is not set in AUTO MODE	Check that Laser Engine is set in AUTO MODE (refers to Lighter™ User's Manual)
	Incorrect encoder's type or connection	- Check that the encoder is compatible with the laser marker (see "Encoder" on page 29) - Check that the encoder is working using Laser Engine MOF wizard (refers to Lighter™ User's Manual)
	Incorrect photocell type or connection	- Check that the photocell is compatible with the laser marker - Check that the photocell is working using Laser Engine MOF wizard (refers to Lighter™ User's Manual)
	Inappropriate layout	Check that the layout to engrave is compatible, in terms of marking time, with the MOF application
Red Aiming Beam not visible	F-Theta Lens protection not removed	Check that the F-Theta scan lens protection has been removed
	Laser marker is not in the correct state	Check that the laser marker state is coherent with the AIMING BEAM TYPE property set in Laser Engine Configuration "LASER" (refers to Lighter™ User's Manual)
	Incorrect Aiming beam setting in Laser Engine	Check STANBY POSITION property in Laser Engine Configuration "SCANNER". Depending on the setting, the aiming beam could be not visible because pointed outside the marking field (refers to Lighter™ User's Manual) Check AIMING BEAM TYPE property in Laser Engine Configuration "LASER" (refers to Lighter™ User's Manual) <ul style="list-style-type: none"> • ON: always ON • OFF: always OFF • AUTOMATIC: active only in STANDBY SHUTTER CLOSED state

PROBLEM DESCRIPTION	POSSIBLE CAUSE	ACTION
Red Focusing Beam not visible	The focusing beam output window is obstructed	Check that the focusing beam output window is not obstructed
	Laser marker is not in the correct state	Check that the laser marker state is coherent with the FOCUSING BEAM TYPE property in Laser Engine Configuration "LASER" (refers to Lighter™ User's Manual)
	Incorrect Focusing Beam setting	Check FOCUSING BEAM TYPE property in Laser Engine Configuration "LASER" (refers to Lighter™ User's Manual) <ul style="list-style-type: none"> • ON: always ON • OFF: always OFF • AUTOMATIC: active only in STANDBY SHUTTER CLOSED state
X, Y, Z, R Axis doesn't work	Incorrect integration	Check that the Axes control signals are compatible with the external devices used for integration
	Axis is not enabled	Check that the selected Axis is enabled in Laser Engine Configuration (refers to Lighter™ User's Manual)
	Axis is not correctly configured	Check that the selected Axis is correctly configured in Laser Engine Configuration (refers to Lighter™ User's Manual)
Windows settings are not saved at system restart	C:\ drive is write protected by UWF filter	Follow the procedure present in "Customize the laser marker software" on page 56
Generic I/O signals doesn't work	Incorrect integration	Check that the I/O control signals are compatible with the external devices used for integration
	I/O already used by Axis	Generic I/O and Axes share the same I/O signals. Check that the selected I/O are not used by an Axis that is enabled

REMOTE ASSISTANCE

The laser marker is equipped with a remote connection tool that can be used for diagnostic purposes by Datalogic technical support.

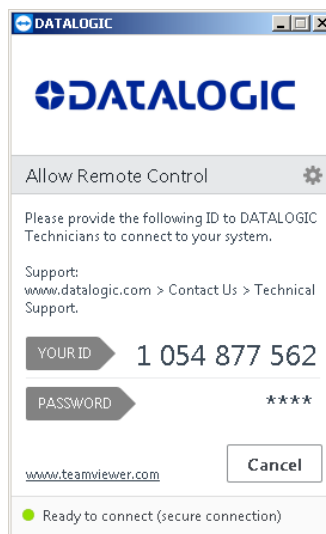

NOTE: The laser marker must be connected to the Internet.

APPENDIX A

LABELS

LABELS

LABEL	DESCRIPTION
	Identification label
	Warning laser logotype
	Laser Label ¹
	Aperture Label
	Label for non-interlock protective housing
	Caution, possibility of electric shock
	USB port
	MAC Address
	Windows 10 IoT Enterprise COA
X1	Command Box connector
X2	Control Axes connector
INTERLOCK	Interlock connector
INLET AIR	Inlet air
LAN	LAN port
RS232	RS232 port
VGA	VGA port
PHOTOCELL	Photocell connector
ENCODER	Encoder connector
 2xT5A	Fuses

1. Maximum output of laser radiation as per definition 3.55 of IEC60825-1 considering single fault conditions.

POSITIONING OF EXTERNAL LABELS

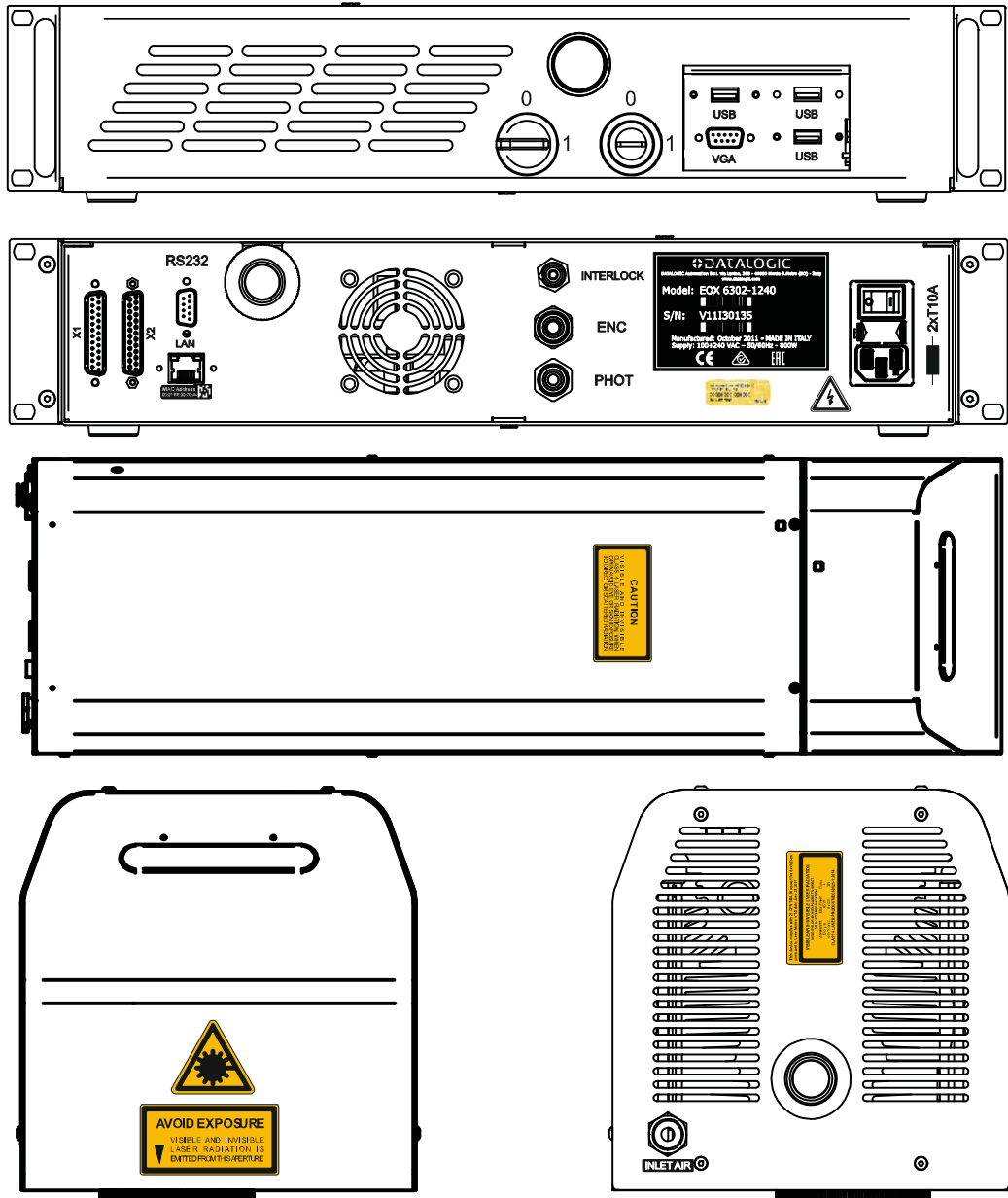

Figure 53: External labels location

APPENDIX B

LASER SAFETY



WARNING: The laser marker is designed for the processing of non-flammable materials.

Infrared laser radiation carries very high energy: **FIRE HAZARD!**

Do not direct the laser beam at flammable materials (paper, wood, containers filled with flammable liquids, etc.) without taking suitable precautions (inert gas, etc.).

Do not direct the laser beam at sloping surfaces as there is a risk of reflection.

Keep solvents and flammable materials away from the laser marker. Avoid the accumulation of combustible vapors.



WARNING: When marking materials using CO₂ laser radiations, decomposition products may form which are harmful to man's health.

The vaporization of certain materials may generate ultra-fine dust and vapors containing carbonization products which are harmful to man's health.

We strongly recommend installing an adequately sized extraction system equipped with filters suited to the dust and fumes to be extracted.

Certain processes may generate fumes and vapors of such density that they cause the extraction system to become totally ineffective in a very short time.

Periodically check for proper operation of the extraction system.



WARNING: Zinc Selenide!

The laser marker uses a special focusing lens (mounted on the scanning head) in Zinc Selenide (ZnSe).

When broken down to dust and fragments, this material is toxic for man's health if inhaled, swallowed or in case of eye contact.

There are no health hazards under normal operating and maintenance conditions.

Do not scratch the lens while cleaning it.

In case the lens breaks, wear protective gloves and clean up all lens pieces, putting them in a sealed bag to be sent back to Datalogic.

The following information is provided in compliance with regulations set by International Authorities, and it refers to proper use of the laser marker.

LASER RADIATION

Laser radiation is an electromagnetic emission with a micrometric wavelength which ranges from the long infrared (CO₂ Laser), close infrared (Nd Laser: Yag, Nd: YVO₄), visible (He Laser: Ne or Argon) and ultraviolet (excimer laser).

It should be considered non-ionizing Radiation. In the Eox laser marker the emission is generated by CO₂ tube. The continuous reflection of Photons, between a front mirror and rear mirror, creates a positive reaction so that their number continues to increase, until reaching the concentration necessary to produce a beam which projects from the semi-reflecting front mirror. The radiation (which we can imagine as a “Beam of invisible light”) is then Collimated and Focused with Lenses at a point where the intensity becomes high enough to be able to react with various materials producing an alteration in them due to thermal effect.

The radiations of laser marker are visible and invisible. The eye doesn’t have any natural defense against invisible radiation! Added to this is the fact that it is generally very intense, with the result that it can be very harmful to the eye and present vision problems.



WARNING: Directly viewing a laser beam can cause irreversible damage to human eye.

To prevent permanent damage to vision, a few precautions must be taken.

All individuals who may be exposed to dangerous levels of laser radiation, must know that the laser is active and wear protective goggles if necessary.

Due to its high power, the laser integrated in the Datalogic system provokes reflected laser light from flat surfaces. Reflected light is potentially dangerous for the eyes and skin. Electromagnetic emission with a micrometric wave length is placed in long infrared, and is therefore invisible, thus it is not clear where reflected beams are aimed.



WARNING: Viewing of a reflected laser beam can cause irreversible damage to human eye. The use of accessory external optics may increase the risk of damage.

In addition to possible injury to the eyes or skin, direct laser emission can cause flammable materials to burn like organic solvents (alcohol, acetone) or gasoline and cause fabric and clothing to burn.



WARNING: This laser marker is classified as Class 4. Class 4 includes lasers which can produce risks, not only from direct or reflected radiation, but also from scattered radiation! The laser marker may be a significant risk for the skin and risk of burning flammable materials.

ABSORPTION OF LASER RADIATION

Human tissues absorb electromagnetic radiation in different ways depending on tissue characteristics and the wavelength of the radiation. Certain wavelengths may be transmitted or absorbed, in different levels, by the human tissue. In the specific case of the eye, the Cornea and Crystalline lens allows most of the radiation within the wavelength range of 400nm to 1400nm to pass and reach the retina (where are the vision sensors). This range includes the visible light as wells as near-infrared. The Eox™ laser markers emit in the 10600 nm range and thus can not be focused by the eye lens at retina.

Regarding human skin, the tissue abortion level is higher for the same wavelength range but the maximum exposure tolerance level, before there is a damage, is different compared to eye.

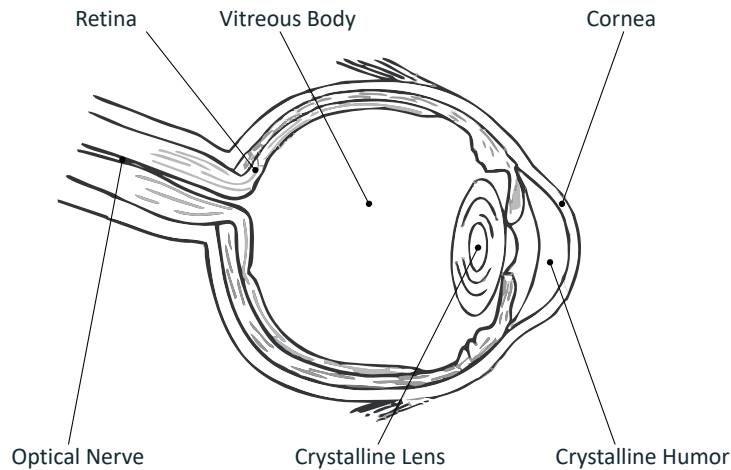

Figure 1: Eyeball section.

The degree of injury depends on the amount of absorbed radiation; the power, energy and peak power of the radiation source, as well as the time exposed to such radiation.

CLASSIFICATION AND DANGER LEVEL

Regulations have established different classes of Lasers, based on their ability to cause human injury. These classes ranges from Class 1 (basically safe in all conditions) to Class 4 (dangerous in several conditions).

Lasers that can produce risk to human being, not only from direct or reflected radiation but also from scattered radiation, belong to Class 4. These lasers sources can also present risk of causing fires through ignition of flammable materials. For these reasons the Customer must, when integrating the laser marker into their machine, implement all necessary measures to contain laser radiation and ensure compliance with applicable safety regulations. All operators using lasers systems should also use appropriated individual protection devices such as goggles, etc.



WARNING: The Eox™ laser marker contain Class 4 invisible laser sources. Refer to applicable regulations (including Laser Safety and Machine safety) for recommendations for compliance of your machine with integration and use of such Class lasers type.

DEGREE OF RISK WITH RADIATION VIEWING CONDITIONS

If F-Theta scan lens is removed from scan head the output radiation is a collimated intense coherent laser beam. The image of such a beam, created by any lens is then a very small spot with extremely high power and energy density. Such a beam is also focused by the human eye and thus result in irreversible damage to the retina. The output radiation of the laser marker, with the F-Theta scan lens, is not a collimated beam but a convergent (before focus plane) and divergent (after focus plane) laser beam. The degree of convergence and divergence depends on the F-theta scan lens specifications and thus varies with the different laser marker models. While marking the laser radiation is typically scattered at the object being marked. Special attention must be taken with objects with high reflectivity to the laser wavelength range since such objects may not only reflect the laser radiation but also change its characteristics according to the shape of such surface (that can work as a lens element). Thus the risk related with laser radiation depends on the characteristics of the beam at which the human is exposed.

In the following sections the risk degree to human eye, related with different viewing conditions, is qualitatively described. Please note that this is intended only as awareness on such risks.



WARNING: It is responsibility of Customer to makes an independent risk evaluation and to implement the necessary safety measures, according to applicable regulations, pertinent to Class 4 Lasers.

Direct viewing of the laser beam

This type of viewing is the most danger for human eye and can occur if looking directly into laser output aperture. Risk is higher in case F-Theta scan lens is removed since output laser beam is, in such conditions, collimated.



WARNING: Do not look directly to laser beam. Individual Protection Devices such goggles do not warrant protection for direct exposure to laser radiation.

Viewing of a laser reflected beam

This may occur when beam is reflected on a mirror surface. This type of viewing is as danger for human eye as direct viewing of the laser beam.



WARNING: Do not look to reflected laser beam. Individual Protection Devices such goggles may only provide protection for a short period of time and thus do not warrant protection for exposure to reflected laser radiation.



WARNING: Many materials, including metals and plastics, have surfaces that strongly reflect laser radiation. Make sure to use non-reflective materials for enclosures or any other machine surfaces that may be exposed to direct or indirect laser beam radiation. Pay special attention when marking objects with high reflectivity properties.

Viewing of scattered laser beam

This is the most typical exposure condition when laser is scattered by at a non-reflective surface (such as blocking element or when marking of some materials). In this case, special filter windows and Individual Protective Devices (such as goggles) may allow full protection even for prolonged exposures if is such protective means respect applicable norms for the type of laser radiation.



WARNING: Always use certified protecting goggles appropriated for the laser radiation characteristics to which you can be exposed.



WARNING: Remember that none goggles can provide sufficient protection for prolonged direct or reflected laser beams.

N.O.H.D. DETERMINATION AND O.D. OF PROTECTION GOGGLES

In order to determine the characteristics of the protection goggles, it is essential to determine the characteristics of the radiation, knowing its optical path, the dimensions of the beam and its divergence.

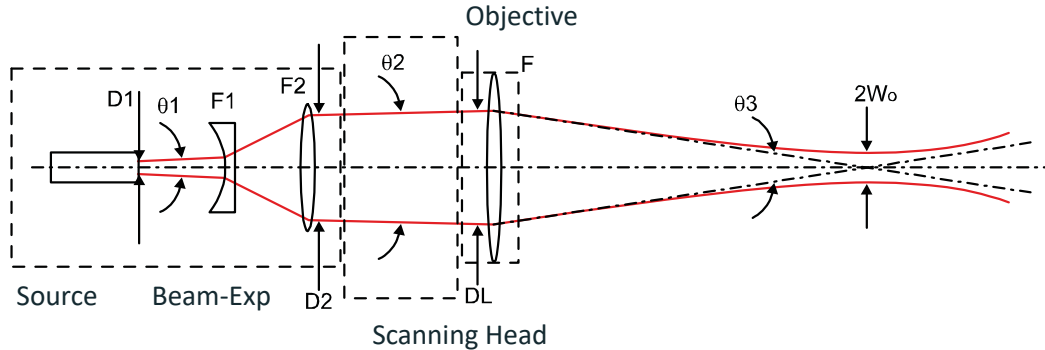

It is very important to know the real divergence of the laser beam at the output of the F-Theta scan lens.

With the availability of these optical data, it is possible to calculate the Nominal Ocular Hazard Distance (N.O.H.D.) and the Optical Density (O.D.) required by the laser radiation protection filters (goggles).

Below results have been done considering Directive 2006/25/CE on the minimum health and safety requirements regarding the exposure of workers to risks arising from physical agents (artificial optical radiation). The user must check if Directive 2006/25 / EC was implemented as a law in his own country and regulate himself accordingly.

Only accidental direct exposure has been considered (exposure time = 10 s).

PARAMETER		EOX 6302-1241	EOX 6302-1541
Wavelength	nm	10600	
Max Power	W	30	
M ²		1.2	
Beam Diameter (DL)	mm	5	
Working Distance (WD) ^a	mm	100	200
Real Divergence after the lens (θ_3)	mrad	50	25
N.O.H.D. ^b	m	4	8
O.D. ^c		> 3	

- a. See Note on page 23
- b. Assuming the F-Theta scan lens as reference point
- c. Assuming the F-Theta scan lens as reference point, this O.D. is valid for a distance greater of 0.5 m + WD

EN207 and EN208

The O.D. value specifies the attenuation factor that the filter material theoretically has on the beam. However it does not specify the damage threshold of the filter material! The filter material may not be able to withstand the power of a particular laser and may fail instantaneously and result in serious eye injury.

In Europe, two standards have been developed for materials used as filters and frames for laser protective eye-wear and laser protection windows. The EN207 and EN208 norms both specify the damage threshold of the filter material used.

The EN207 standard is used for full attenuation, these filters are used to completely block the wavelength for which they are specified.

The EN208 standard is used for partial attenuation, these filters are used only in the visible range 380-700nm where they reduce the beam intensity down to the Maximum Permissible Exposure (safe level). They are particularly useful for alignment where seeing the beam is necessary.

Safety goggles are labeled according to EN207 or EN208 as appropriate. For example, a filter labeled 10600 D LB4 xxx CE means that:

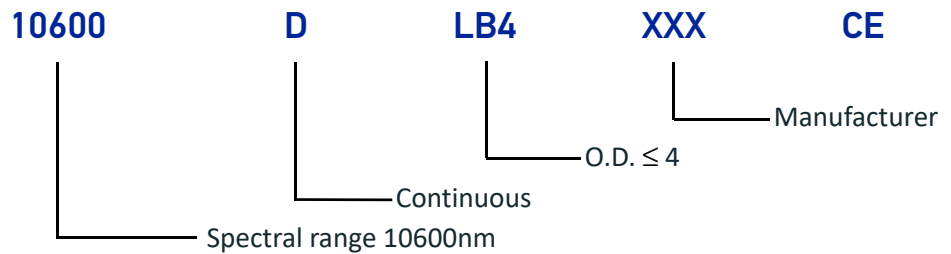

EYES AND SKIN RISKS

If exposed to intense Laser radiation, even of a short duration, or a less intense but longer lasting duration, both the Cornea and the Retina can burn and be damaged irreparably. This is particularly critical for Class 4 laser beam.

If subject to direct focused radiation, even the skin can burn.

GENERAL SAFETY REGULATIONS

The user of the laser marker must comply with all regulations and work best practices regarding safety. Therefore it is necessary to develop a Standard Operating Procedure (S.O.P.) related to operations of the machine incorporating this laser marker. This procedure, shall be available at time of installation, shall serve as a reference for the Operator and shall be written in his/her language.

Training is essential and must include:

- Familiarization with system operating procedures.
- Knowledge of the biological effects of radiation on the Eyes and Skin.
- Understanding of the necessity for Individual Protection Devices (I.P.D.)

OTHER RISKS

An additional risk may be represented by fire caused by processing materials other than those the laser marker was designed for.



WARNING: Do not use this laser marker for other purpose than the one it was designed for.

Another additional risk associated with the laser marker is electricity. This may occur when accessing internal parts of the laser marker.



CAUTION: Only Datalogic authorized personnel, who have been trained and instructed on the electrical and optical risks, is allowed to access the internal parts of the laser marker.

Datalogic shall not be held liable for any damage caused by inadequate work from non-authorized personnel.

APPENDIX C

USING MARKING SOFTWARE

HOW TO CREATE AND EDIT GRAPHICS LAYOUT

In “WAIT FOR START” state (refer to “Control the Laser Marker States” on page 34), double click the Laser Editor icon to start the layout editor application.

X1 - COMMAND BOX SIGNAL	STATE
EXT_KEY	OFF
EXT_ENABLE_A	OFF
EXT_ENABLE_B	OFF

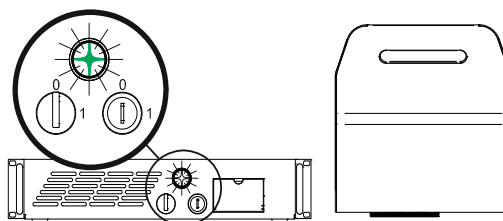

Click on the document type selector and choose **Layer**:

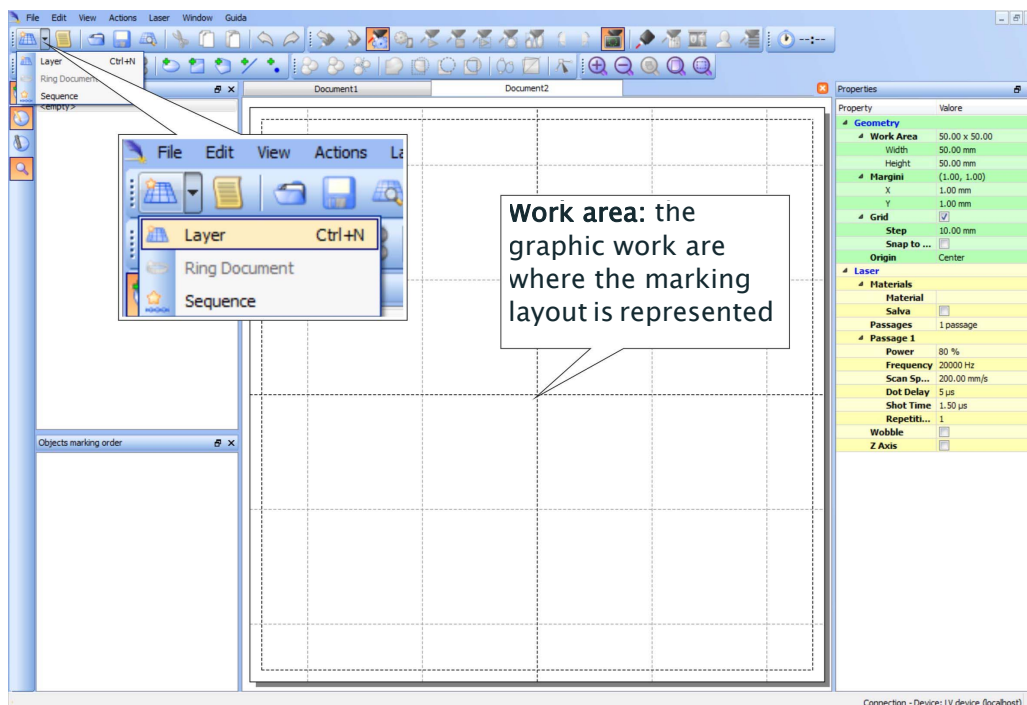

Click on the **Text String** icon in the **Object toolbar** to add a string object to the layer:

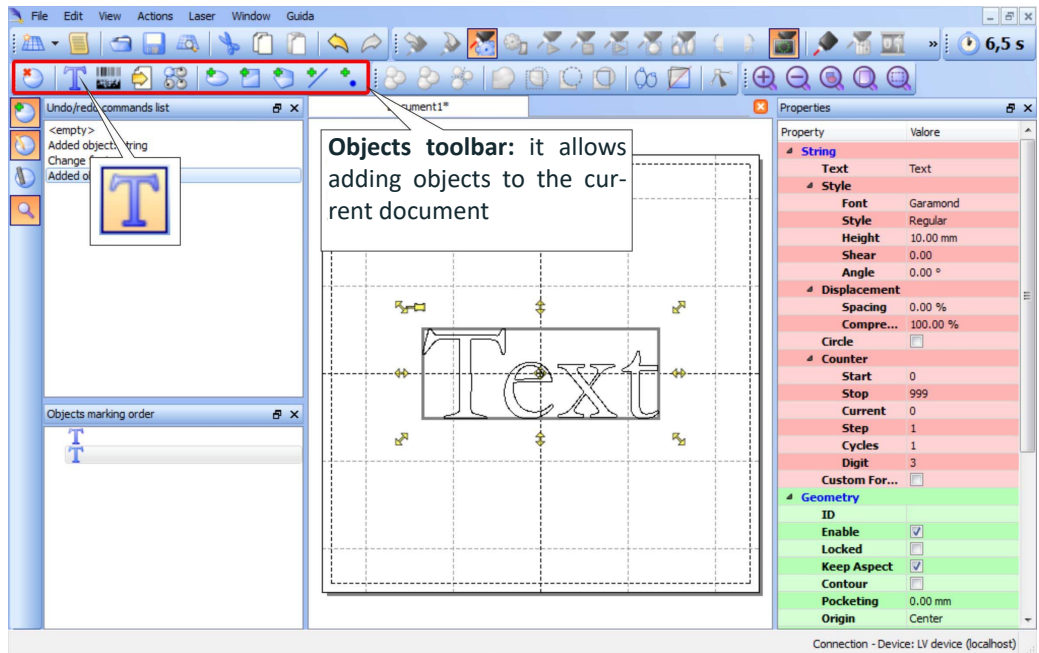

Edit String properties such as value, font, style, etc. using the **Properties browser**:

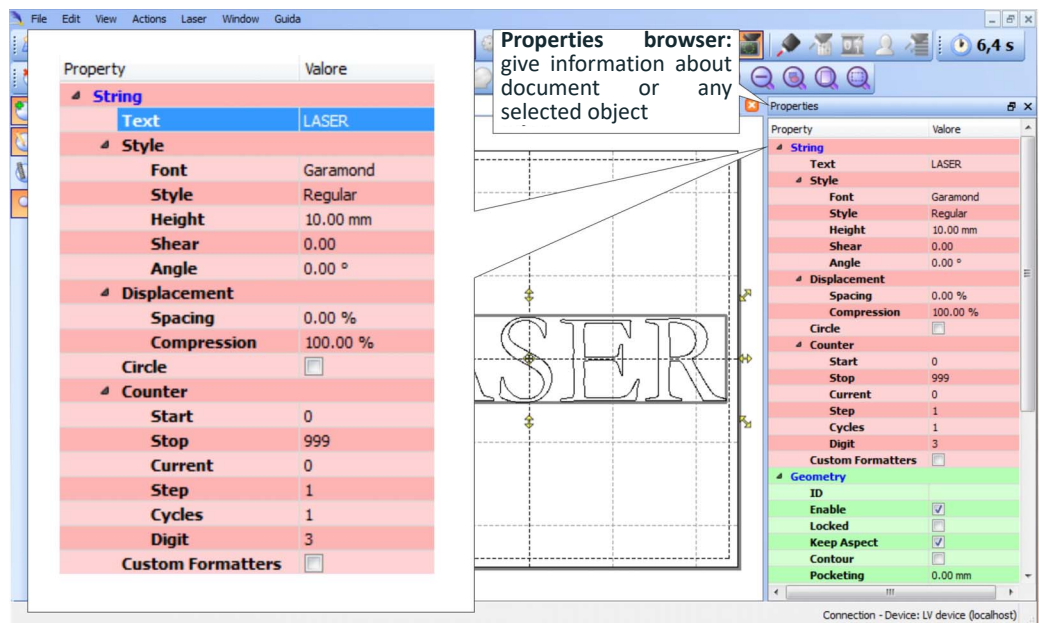

Edit Filling properties such as filling type, interline, etc. using the **Properties browser**:

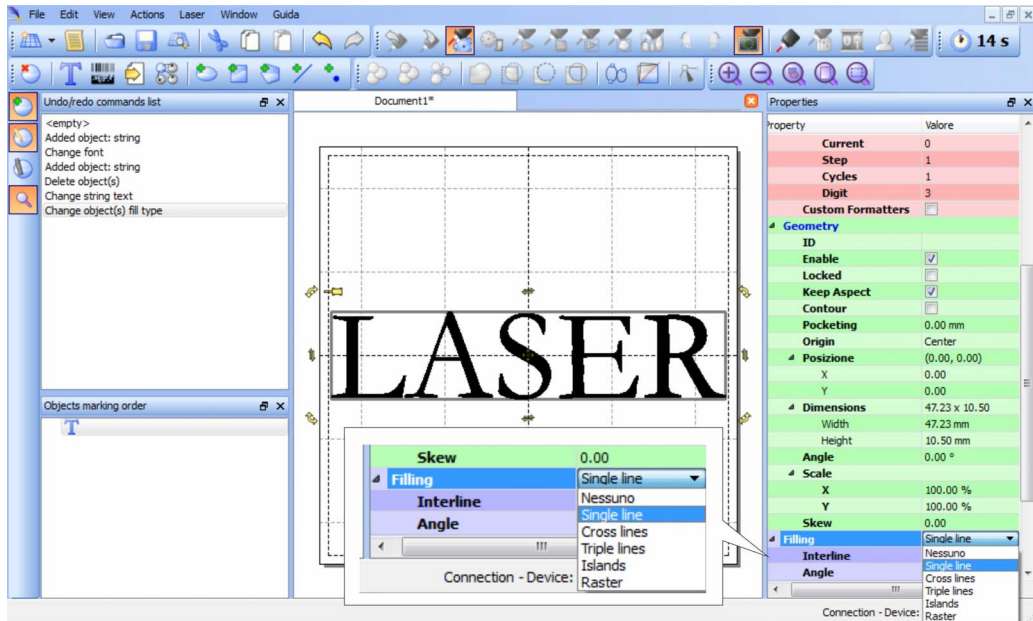

NOTE: Consult **Lighter™** software user's manual for a proper use of the same.

HOW TO TEST AND MARK LAYOUT

In “STANDBY SHUTTER CLOSED” state, press **Limits All** button in the **Laser Toolbar** to adjust the object position in the marking field:

X1 - COMMAND BOX SIGNAL	STATE
EXT_KEY	ON
EXT_ENABLE_A	OFF
EXT_ENABLE_B	OFF

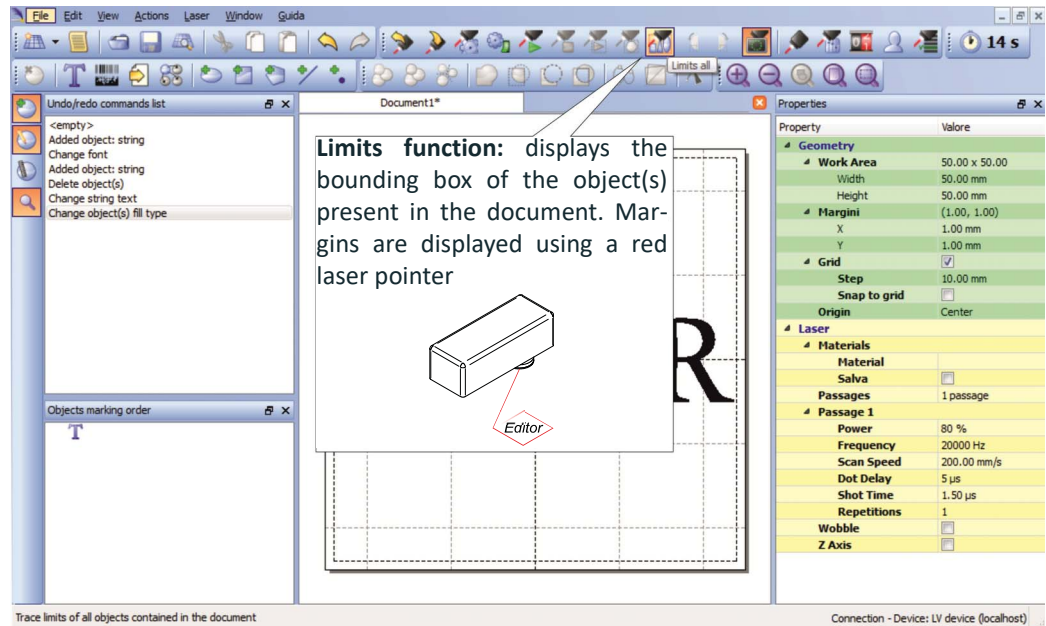
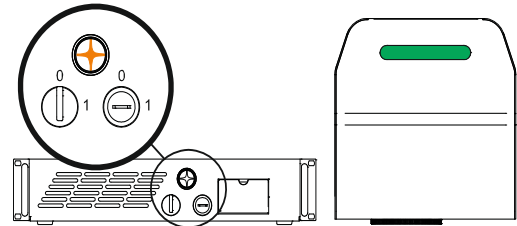

CAUTION: Marking highly reflective materials might cause optical feedback into laser marker. This may result into irreversible damage of the optical components of laser marker.

Verify that the position and geometry of the object to mark does not cause any reflection into the optical aperture of the laser marker F-Theta scan lens.

Please contact our Customer Support Service for support on your particular application.

Optical induced damage caused to laser marker by back reflection from high reflective materials is not covered by warranty.

In "READY" state, adjust the Laser parameters using the **Properties browser**:

X1 - COMMAND BOX SIGNAL	STATE
EXT_KEY	ON
EXT_ENABLE_A	ON
EXT_ENABLE_B	ON

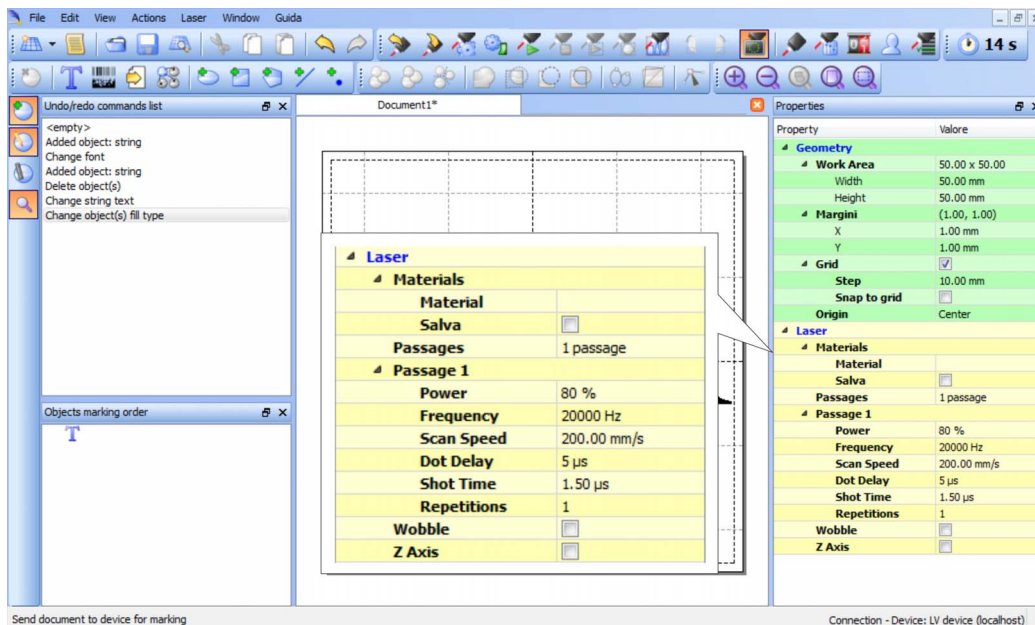
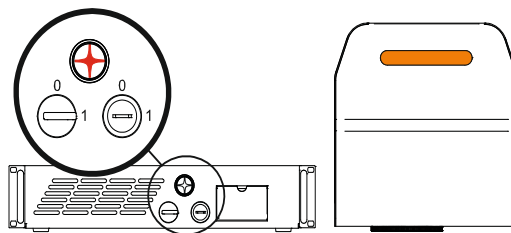

Press the **Send Marking** button in the **Laser Toolbar** .



NOTE: Consult Lighter™ software user's manual for a proper use of the same.

HOW TO USE COMMAND BOX SIGNALS TO MARK LAYOUT

Automate the marking process allowing documents to be marked using external **X1.11** (*START_MARKING*) and **X1.13** (*STOP_MARKING*) signals, which can be generated by PLC or other external devices.

Click on the **Save to Device** button to save the layout in the device memory:

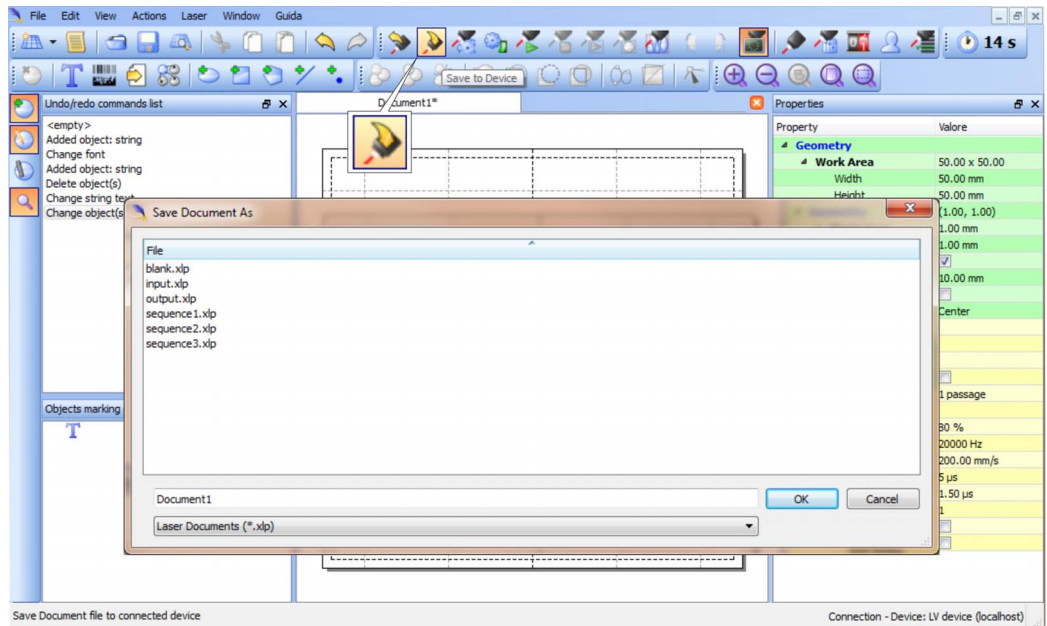

Click on the **Show Laser Engine** button to display Laser Engine window:

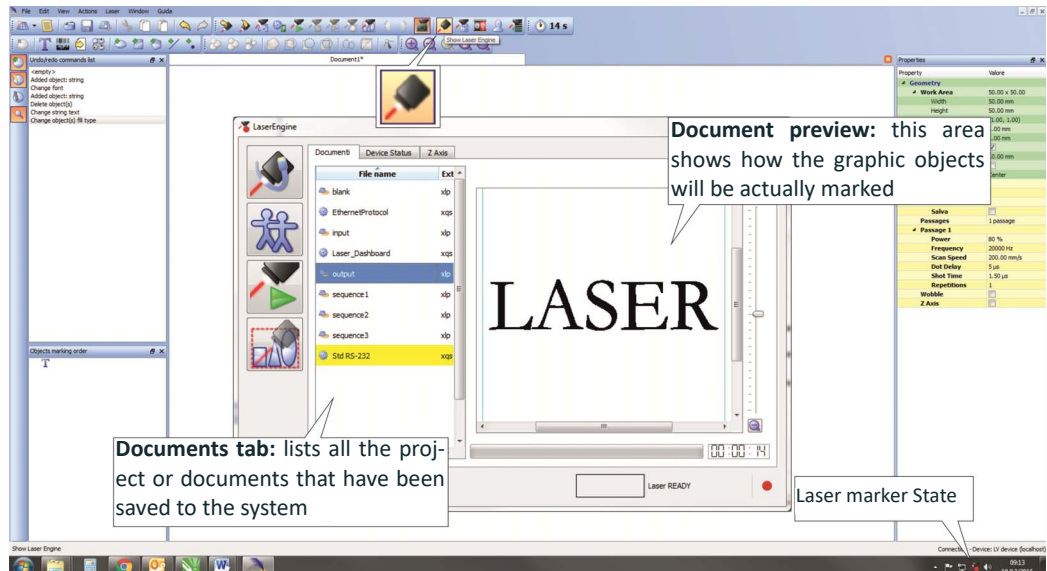

AUTO/MANUAL Mode button allows switching between the two available working modes:

- Auto mode: the engraving operations are executed automatically using external signals.
- Manual mode: used for displaying the margins of the graphic objects to be marked and to test layouts.

Select the document from the list and click on the **To Auto Mode** button:

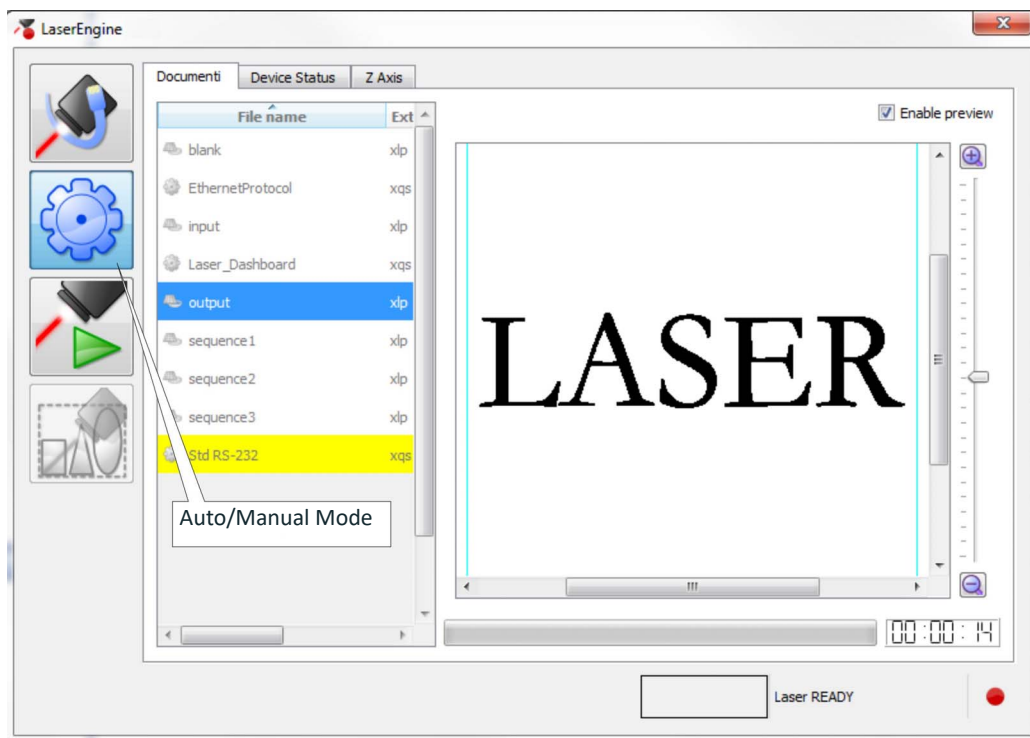

The laser marker is ready to mark the document using external **X1.11 (START_MARKING)** and **X1.13 (STOP_MARKING)** signals:

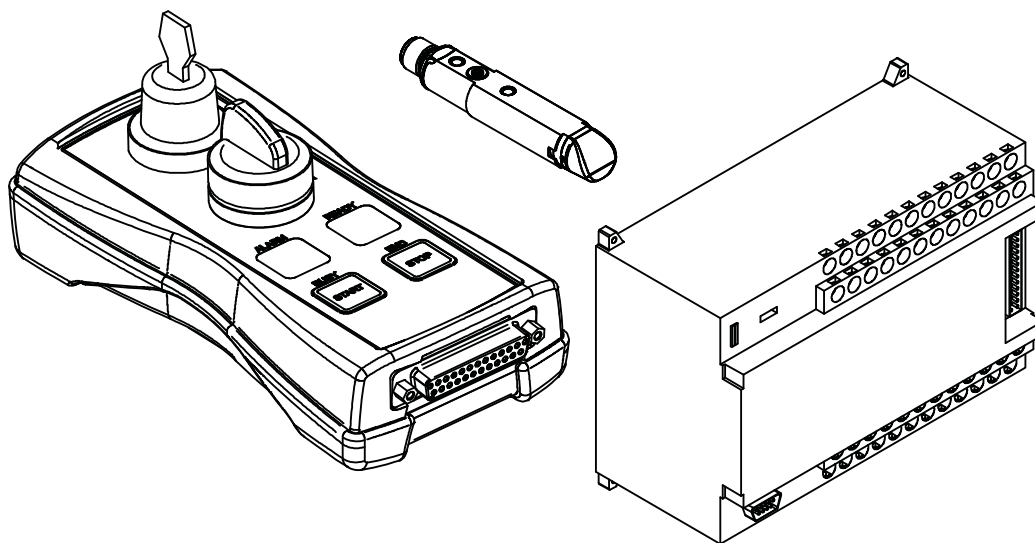

NOTE: Consult **Lighter™** software user's manual for a proper use of the same.

APPENDIX D

MARKING SOFTWARE UPGRADE

HOW TO UPDATE THE MARKING SOFTWARE

This document describes how to update the Lighter™ Suite software version.

Before updating the software, disable system protection (see “Disable the system protection” on page 58).



CAUTION: When the System Protection is disabled the system is not protected against disk corruption or malware attacks. Disable the protection only for the time necessary to make disk changes.

1. Wait for the operating system to **restart**
2. Check that the System Protection is **disabled** (red icon):

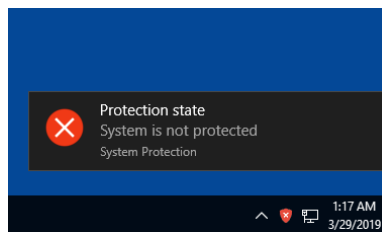

3. Close Lighter™ *Laser Editor* and *Laser Engine* (right-click on the icon in the tray bar and select **QUIT**)

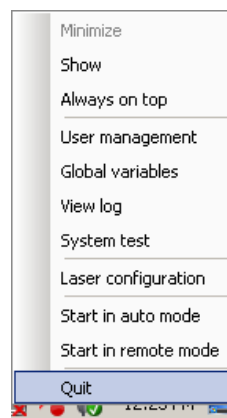

4. Run the new *Lighter™ Suite installer* from an external USB device.

5. Press **Next** to continue:

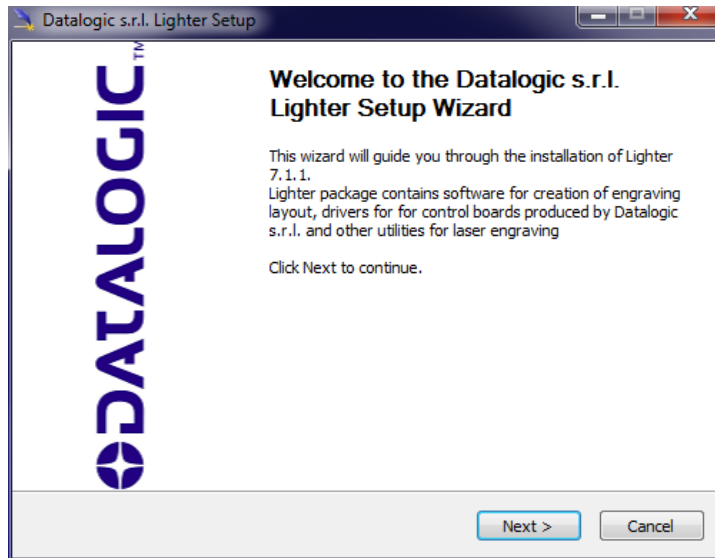

6. Press **I Agree** to continue:

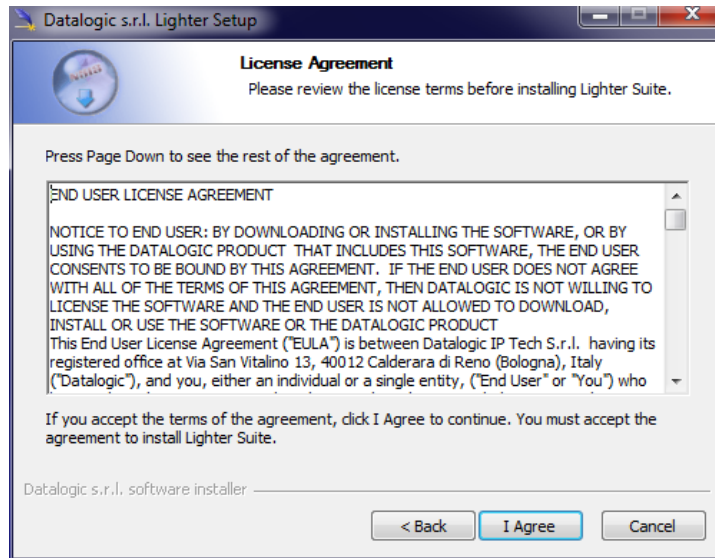

7. Check *"I accept the terms of the License Agreement"* and press **Next** to continue:

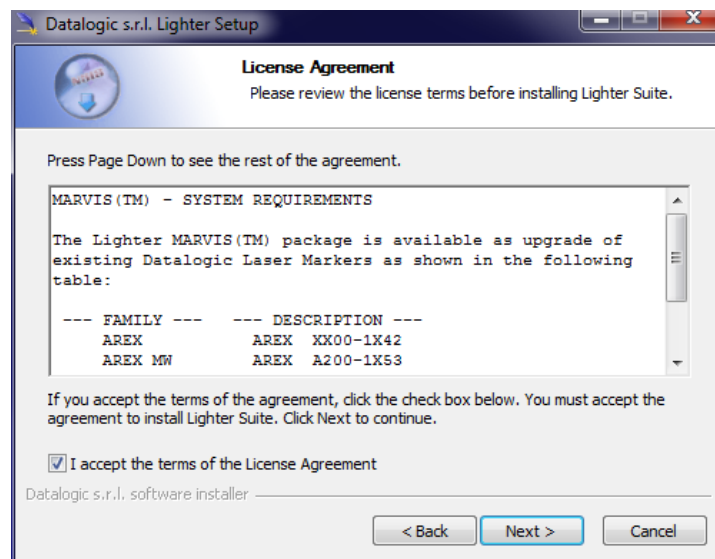

8. Choose the *INTERACTIVE* installation type and press **Next** to continue:

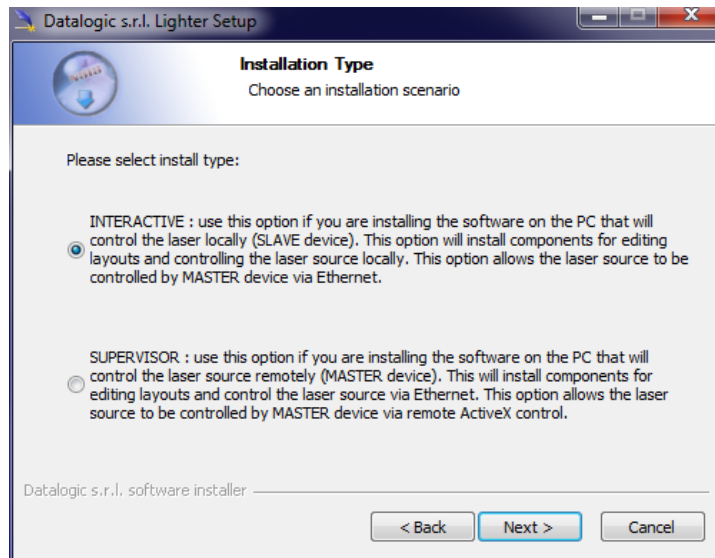

9. Choose the components to install and press **Next** to continue:

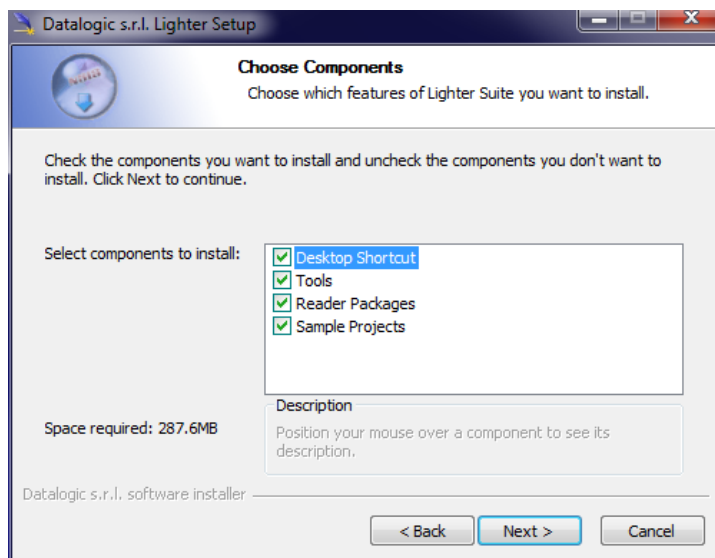

10. Do not change the destination folder and press **Install** to continue:

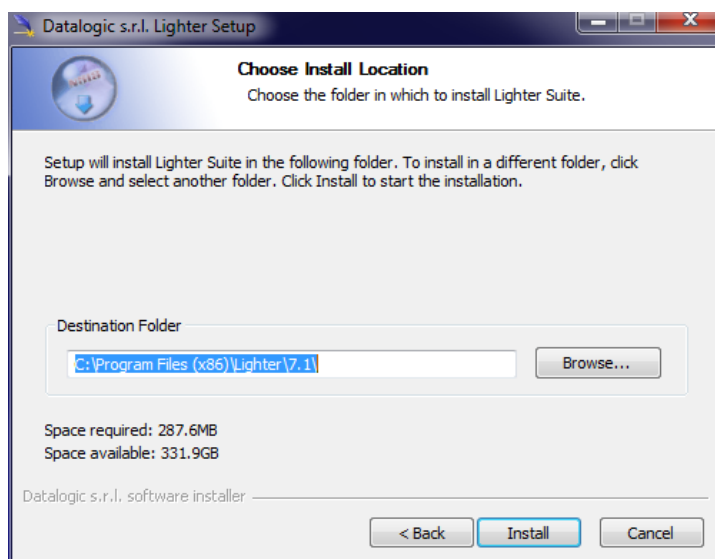

11. Press **OK** to uninstall the old Lighter™ Suite version

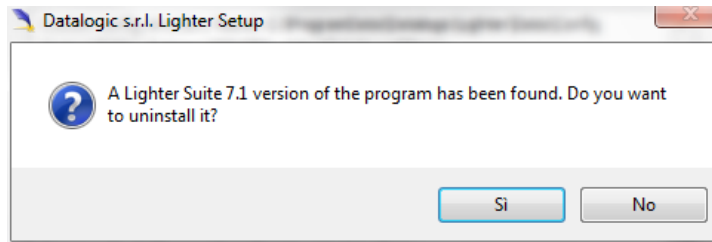

12. Press **Next** to continue:

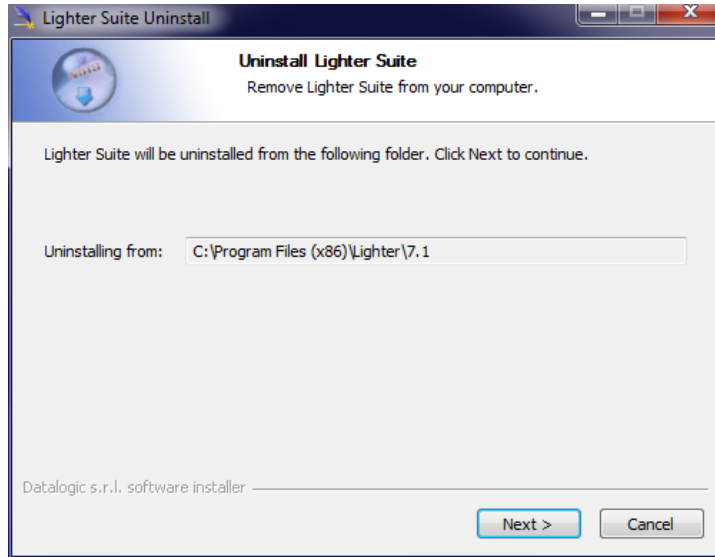

13. Select the components of the old Lighter™ Suite version to remove and press **Uninstall**:

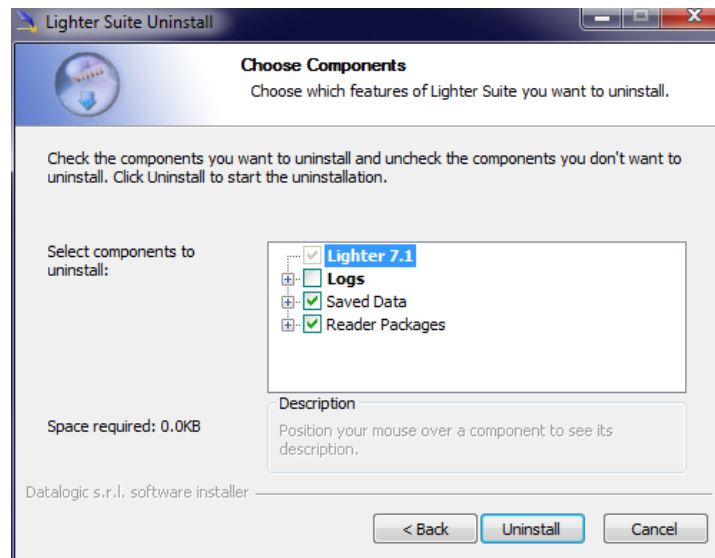

14. Wait until the uninstallation is complete and press **Close** to continue:

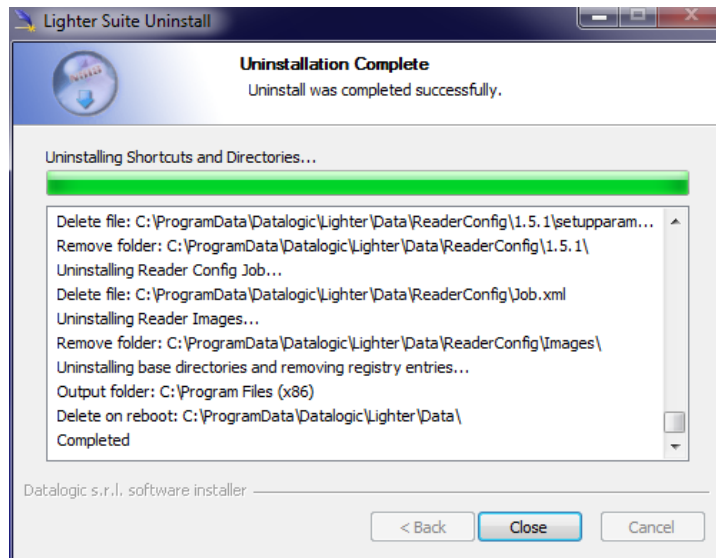

15. Lighter Suite will be installed. Press **Finish** to complete the procedure:

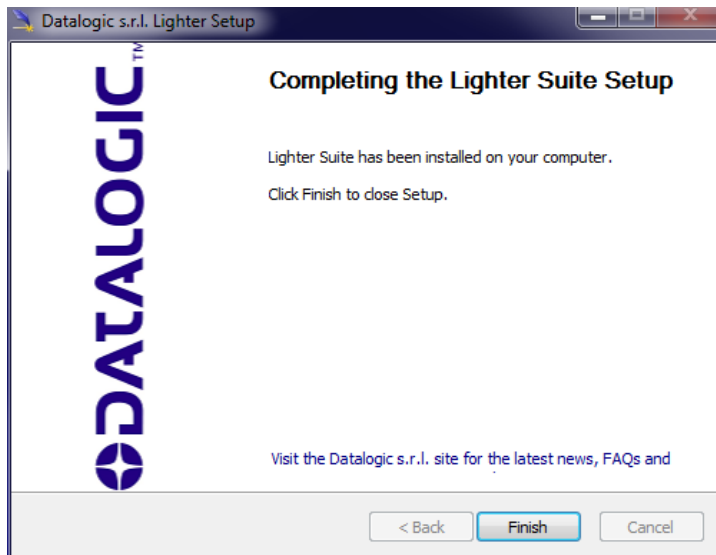

16. If Lighter™ Suite update includes any **control board updates** follow the procedure below otherwise jump to step 17:

- Procedure with laser **control board upgrade**:

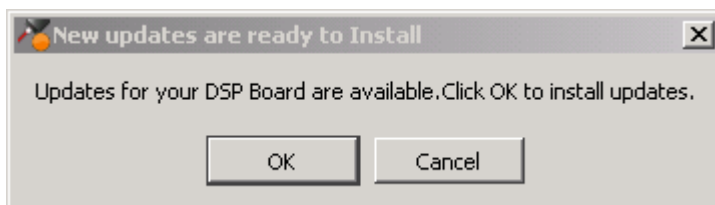

- press **OK** to execute control board update
- wait for the laser control board update

17. Open the System Protection tool GUI

- Click the **ENABLE** button

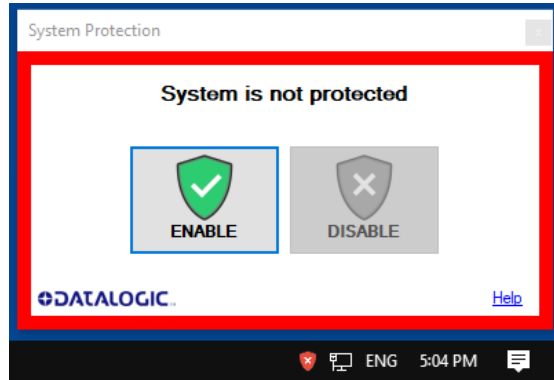

- A message advise the User to confirm the new setting. Press **YES** to enable System Protection

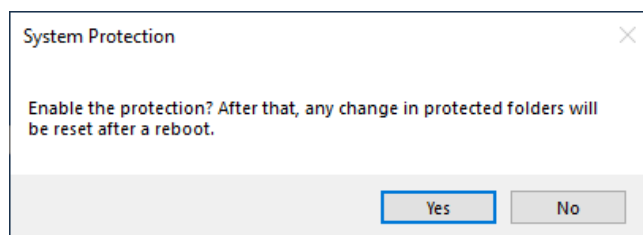

- A message advise the User that the system will be rebooted. Press **NO** to continue

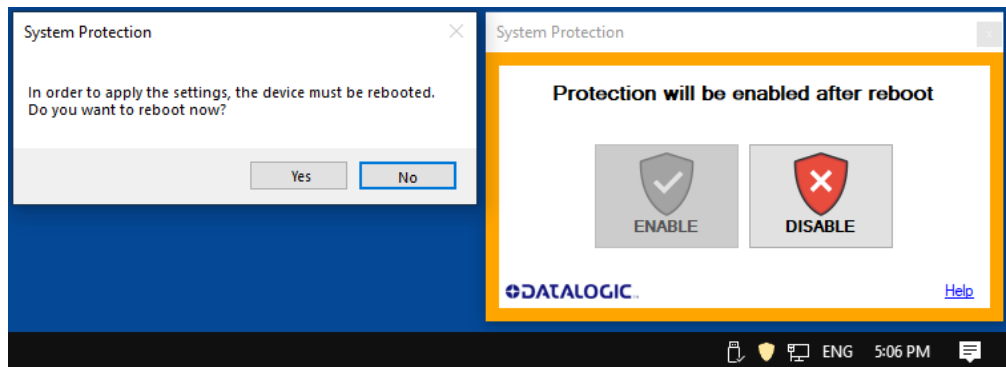

- Shut down the system:

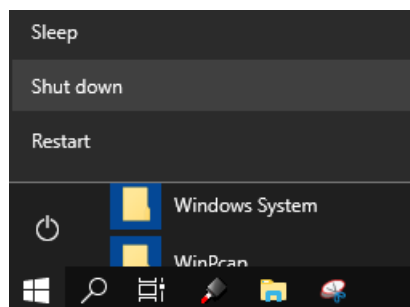

- wait until the operating system shuts down (black screen)



CAUTION: DO NOT turn OFF or UNPLUG the laser marker while Windows® is shutting down!

- **POWER OFF** the laser marker to complete installation

APPENDIX E

RECOVER THE LASER MARKER

OVERVIEW

The laser marker is provided with a *RECOVERY partition* able to restore the system to the factory settings.

The RECOVERY procedure should be used if the Operating System is corrupted or disks are corrupted.

HOW TO RECOVER THE LASER MARKER



CAUTION: All existing data in the laser marker will be overwritten. All existing data will be lost. If possible, make a backup of all the customer's data located by default in D:\Data folder, before recovering the system.



NOTE: The following images are indicative only.

Preliminary Operation

Before proceeding with the recovery procedure, it is necessary to get the original factory configuration file (`laser.inz`):

1. From an external PC connected to the Internet, go to [Datalogic](#) web site and click on **PARTNER LOGIN**.
2. If you are not registered yet, you will be asked to **Create your login**.
3. Enter **Username** and **Password**.
4. Select **TECHNICAL** and click on **LASER MARKING CONFIG. FILES REPOSITORY**.



5. Insert the **Serial Number** and press **SEARCH** button.
6. Select **CLICK HERE** to download the file in **zip** format.



Search by serial number (for example B21M00135)

Configuration file found.
Please **CLICK HERE** to download the file.



7. **Extract** the content of the **zip** file in a USB drive (the file `laser.inz` is contained in the folder **Fileinz and report**).

Recover the system

1. Turn ON the laser marker
2. Wait for '**Choose an operating system**' menu to appears
3. Select '*Change defaults or choose other options*' using **TAB** key and then press **ENTER** key

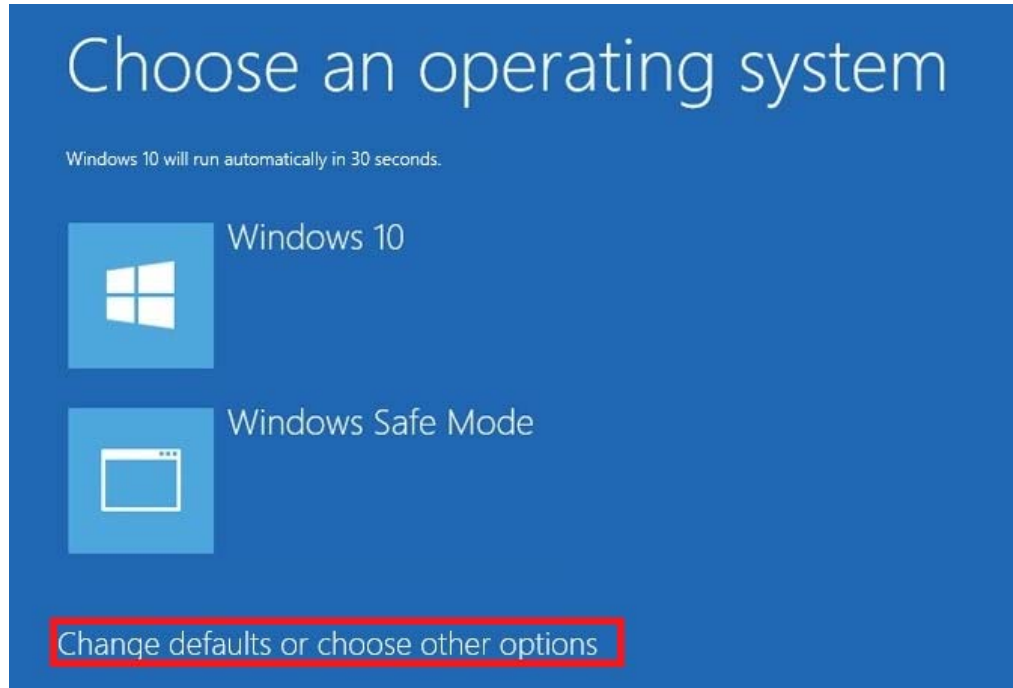

4. The **Options** screen will be shown
5. Select '*Choose other options*' using **TAB** key and then press **ENTER** key

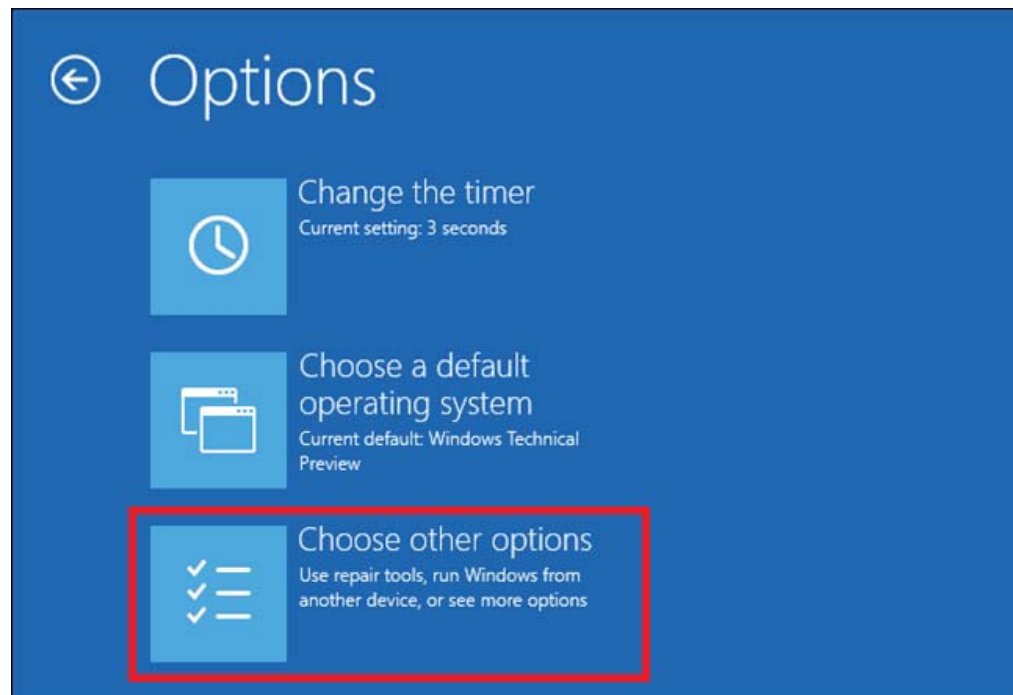

6. The **Choose an Option** menu will be shown
7. Select '*Troubleshoot*' using **TAB** key and then press **ENTER** key

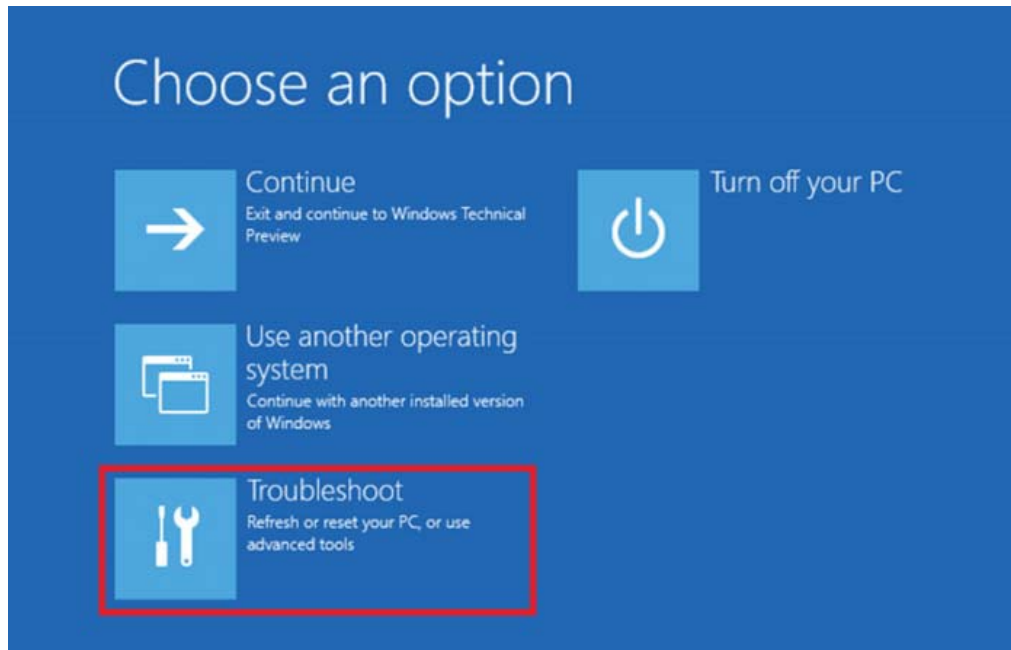

8. The **Troubleshoot** menu will be shown
9. Select '*Advanced Options*' using **TAB** key and then press **ENTER** key

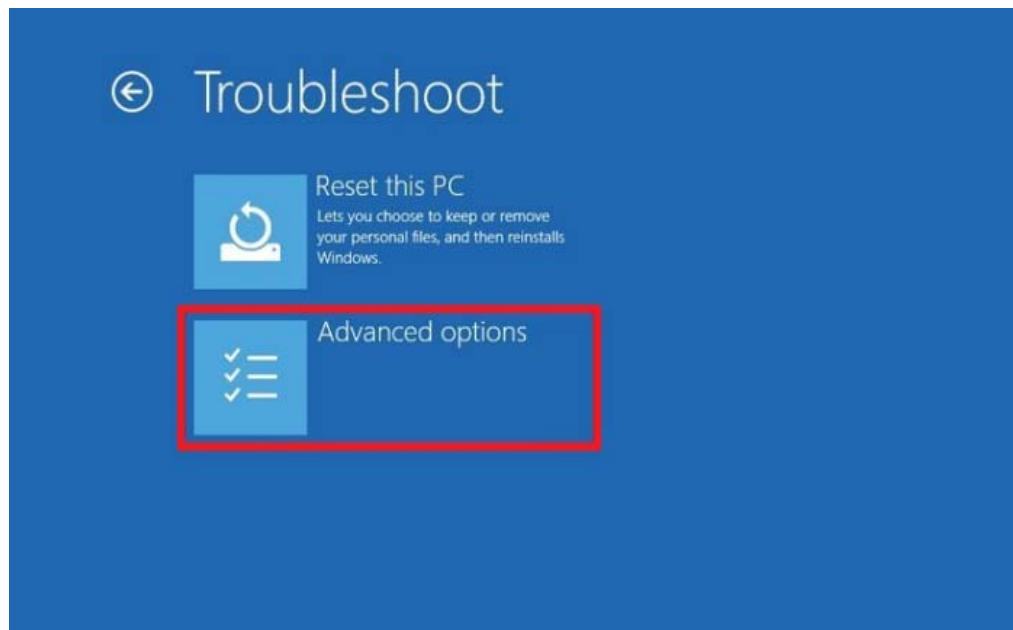

10. The **Advanced options** menu will be shown

11. Select '*System Image Recovery*' using **TAB** key and then press **ENTER** key

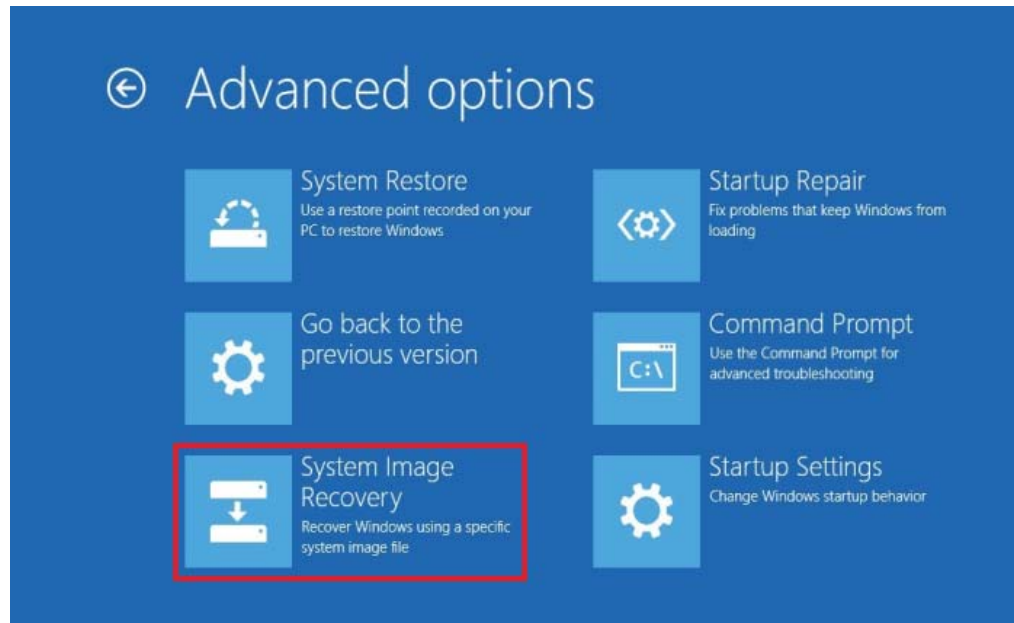

12. Enter the password '*dla*' and press **CONTINUE**

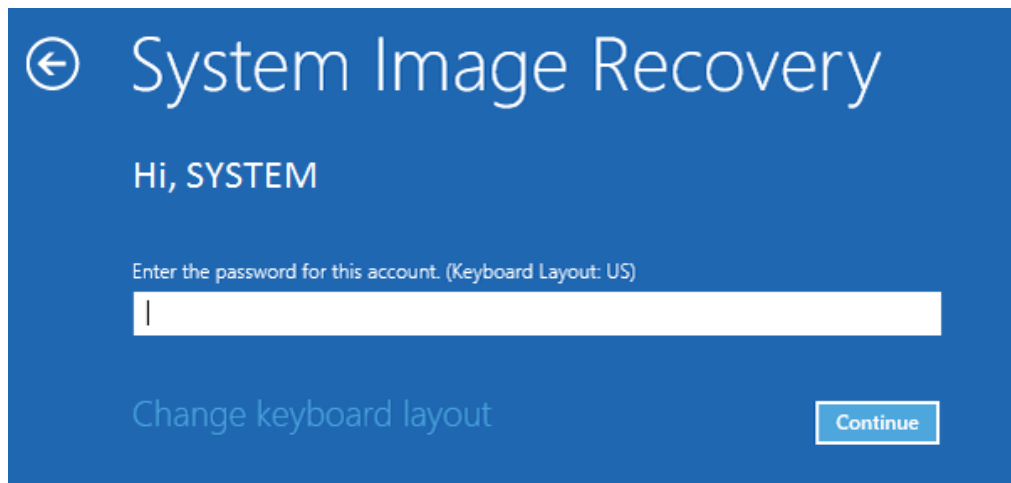

13. Select 'Use the latest available system image (recommended)'

14. Press **NEXT** to continue

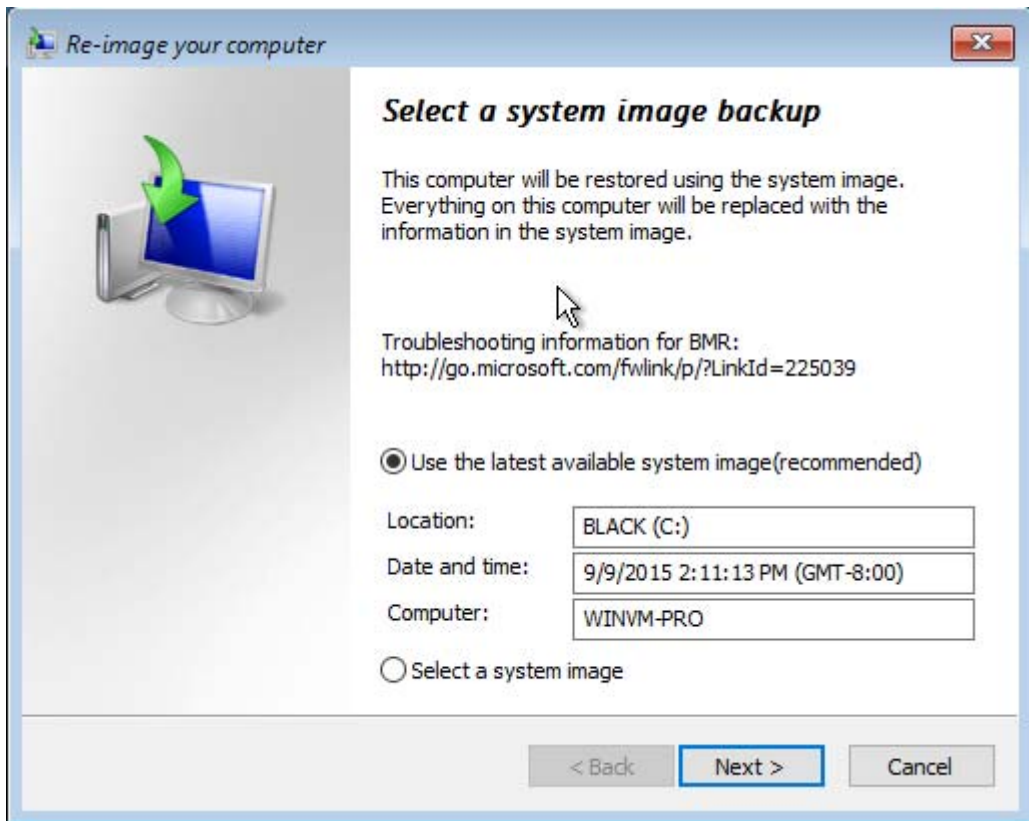

15. Press **NEXT** to continue

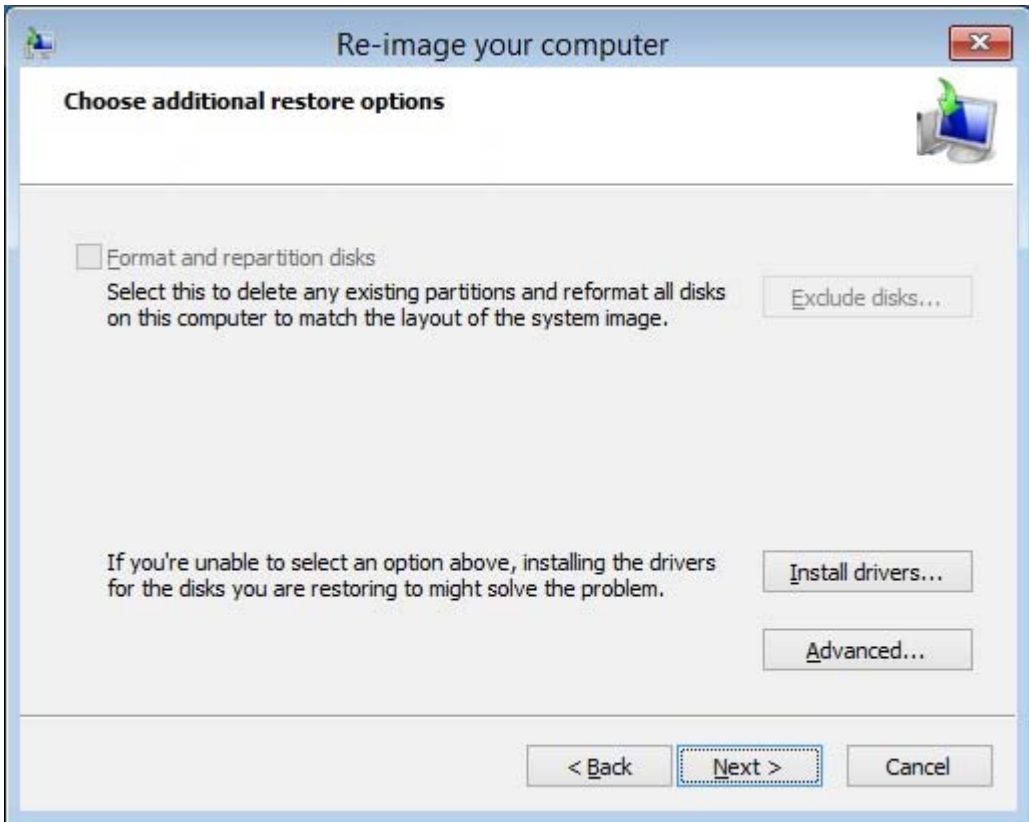

16. Press **FINISH** to continue

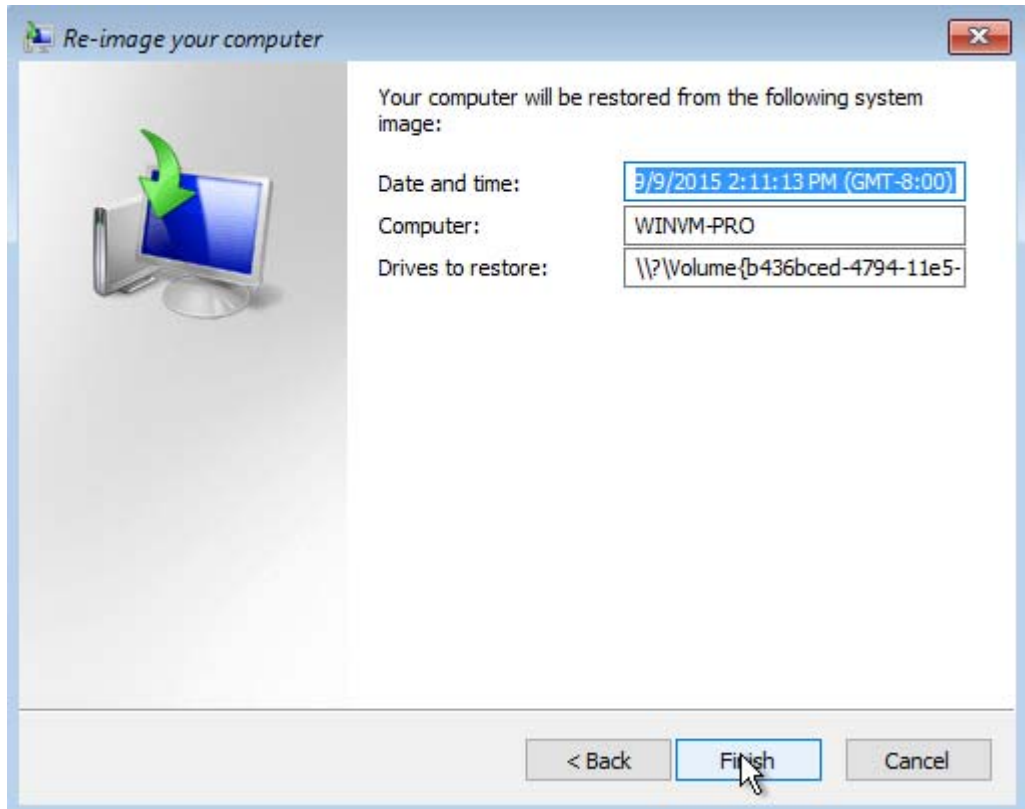

17. Press **YES** to continue

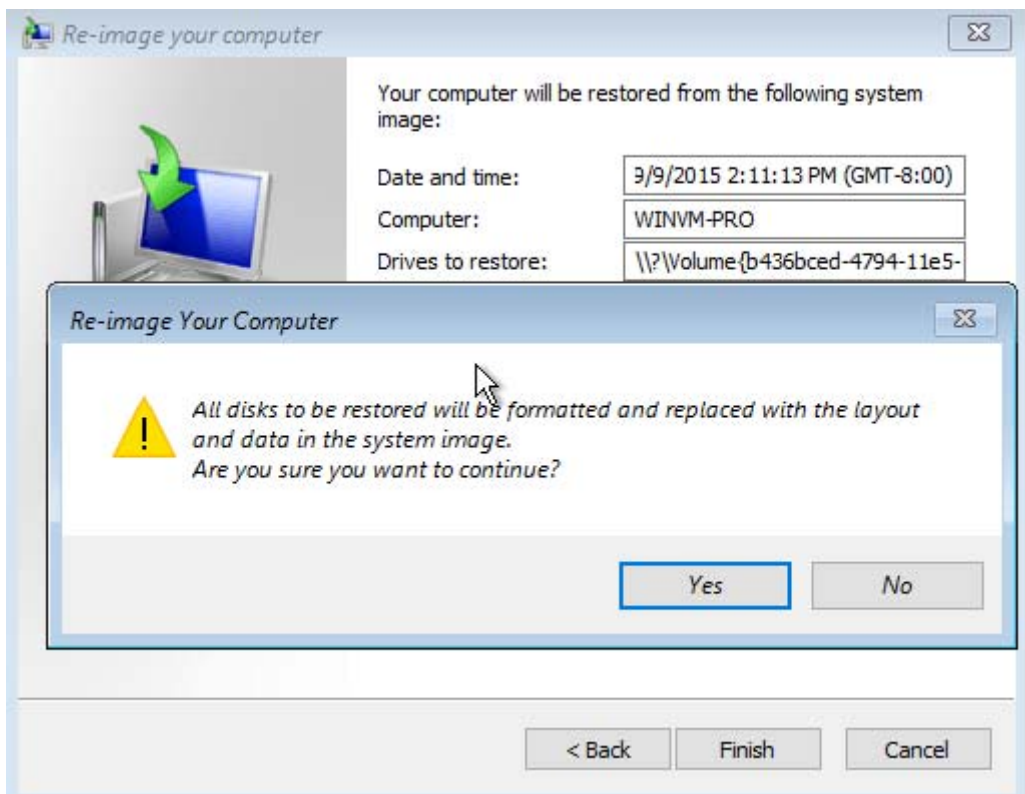

18. **Wait** for disks restoring

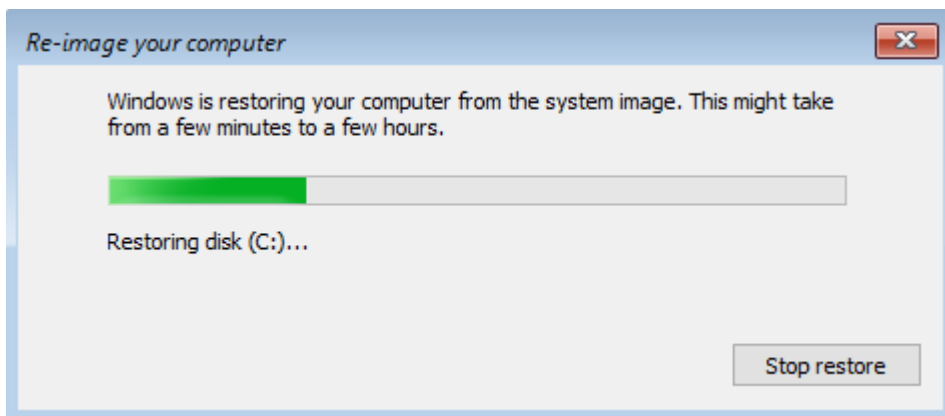

19. The system will **restart** automatically

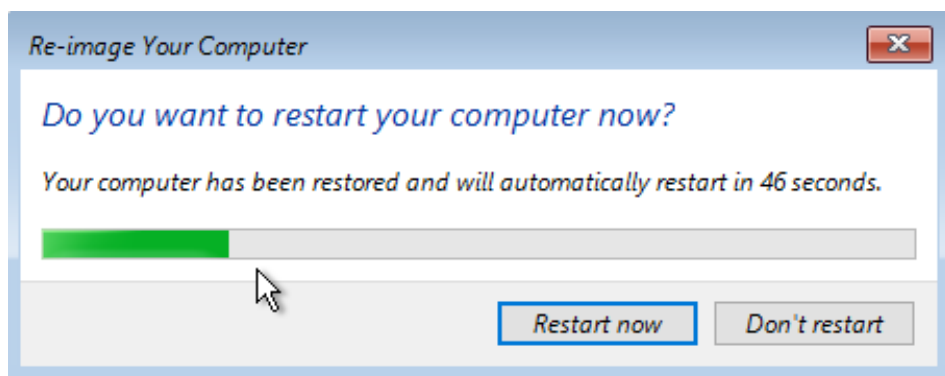

20. **Turn ON** the system

21. The system will perform the *New Hardware Configuration* procedure (approx. 2 minutes)

22. **Wait** for the end of the procedure

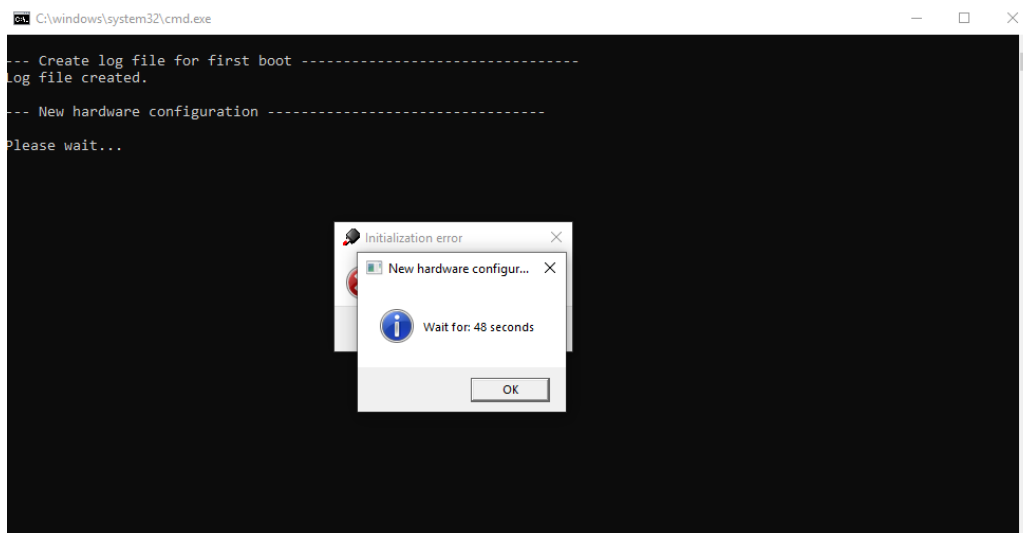

23. The system will **restart** automatically



CAUTION: DO NOT turn OFF or UNPLUG the laser marker while Windows® is restarting!

24. After the restart an error message will advise you that Lighter™ initialization file is not present. Press **OK** to continue:

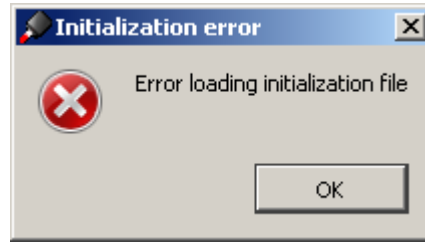

NOTE: In order to work, the marking software must be customized with the factory configuration file. The custom `laser.inz` file is present in the Partner Area of the Datalogic website (see “Preliminary Operation” on page 104).

25. Insert the USB drive with the `laser.inz` file in a USB port of the laser marker.
26. Navigate to the folder ***Fileinz and report*** and copy customized `laser.inz` to ***D:\DATA\CONFIG***

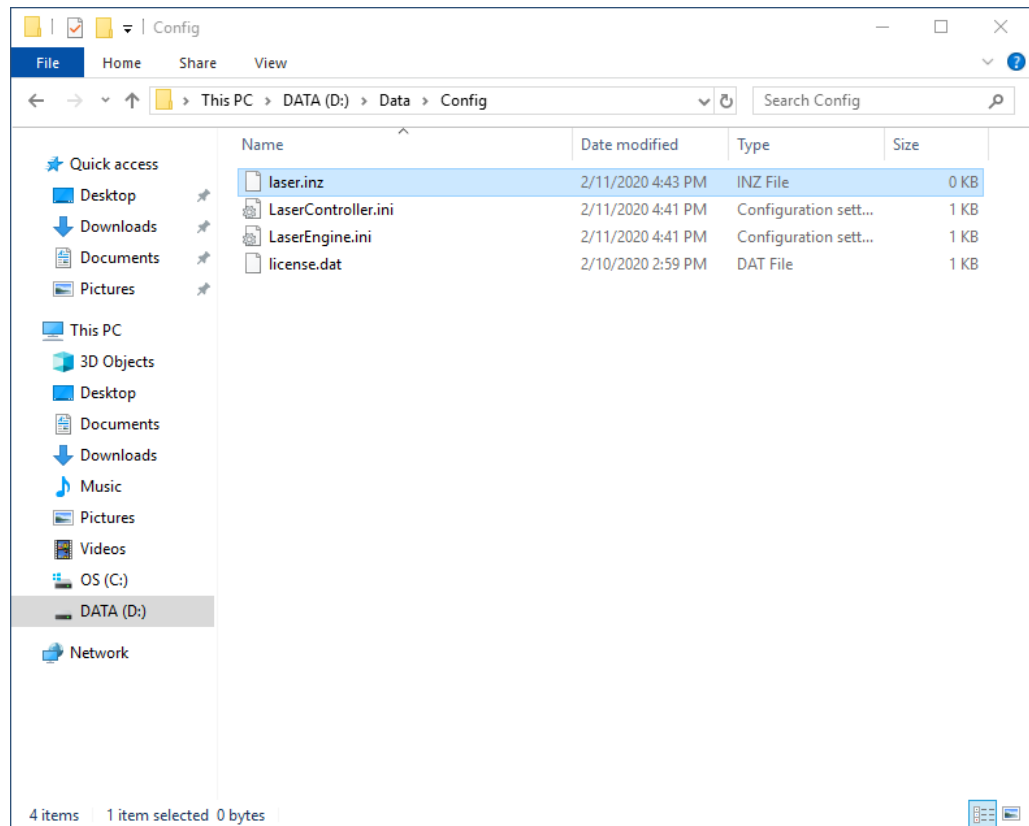

27. Navigate to the folder **Test Layouts**, select the **right test layout** files depending on the laser marker model and copy them to **D:\DATA\DOCS\LAYOUTS**

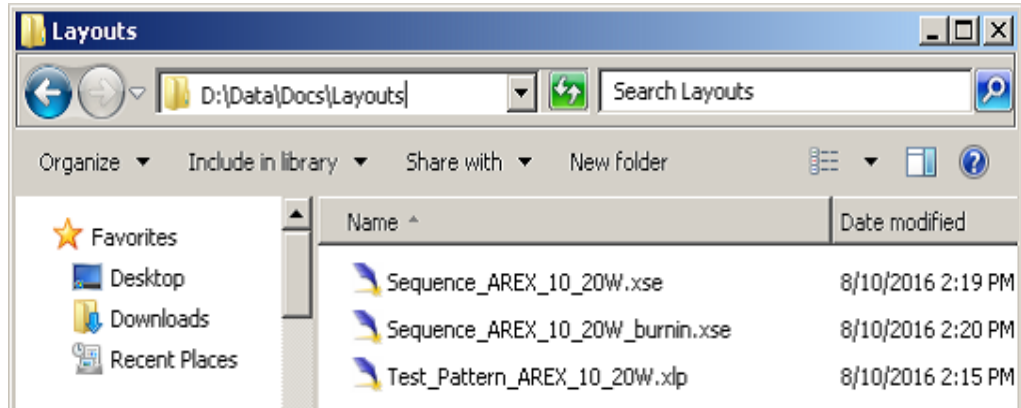

28. **Shut down** the operating system:

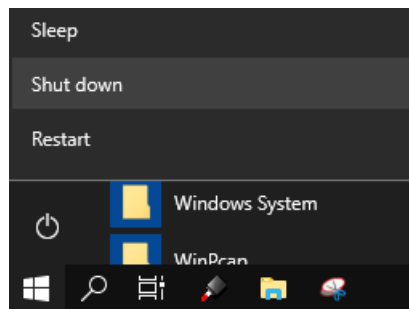

CAUTION: DO NOT turn OFF or UNPLUG the laser marker while Windows® is shutting down!

29. **Wait** until the operating system is shutting down
30. Turn **OFF** the laser marker

APPENDIX F

MECHANICAL DRAWINGS

CONTROL RACK

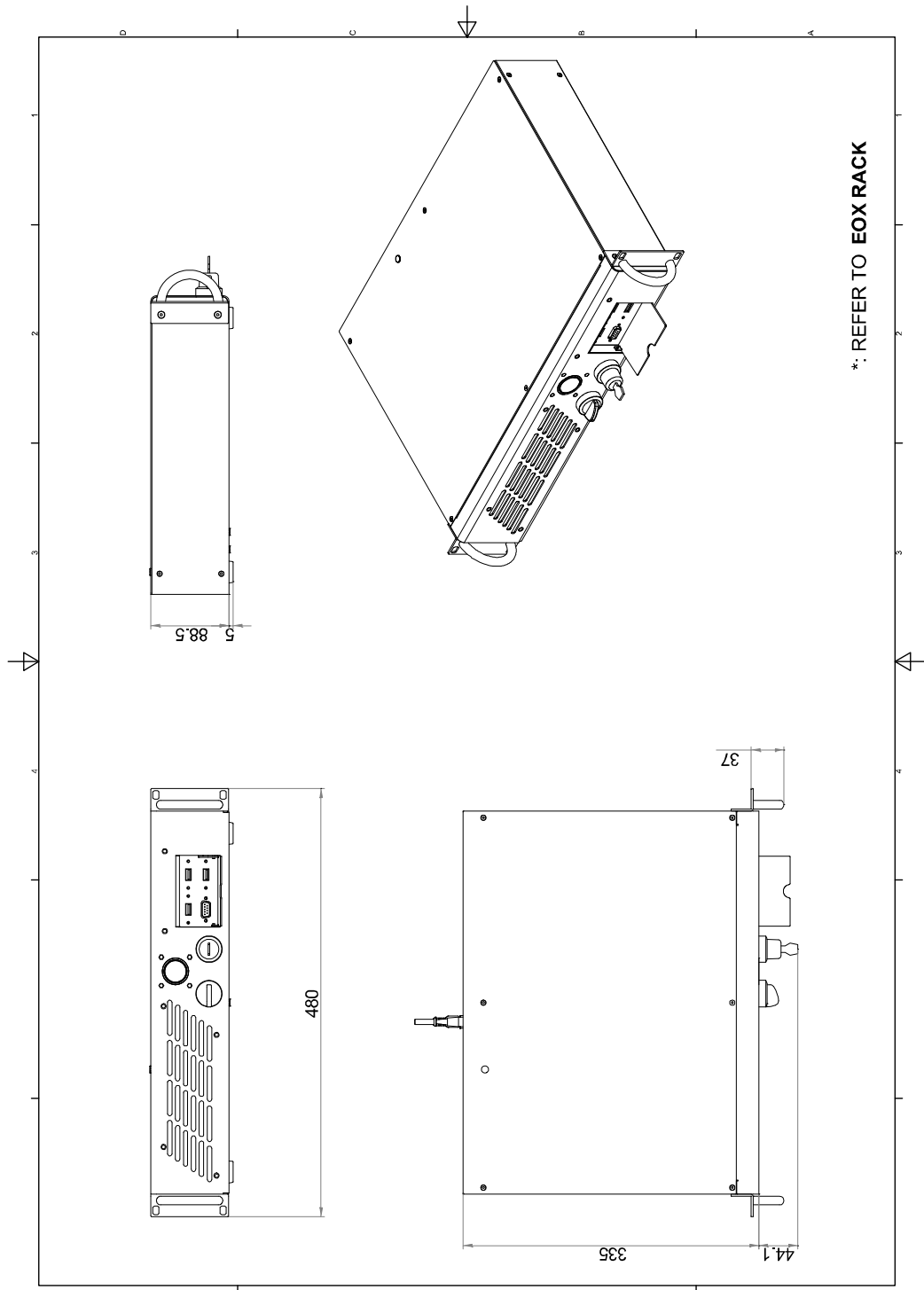

NOTE: Please refer to Datalogic website for detailed drawings.

RESONATOR

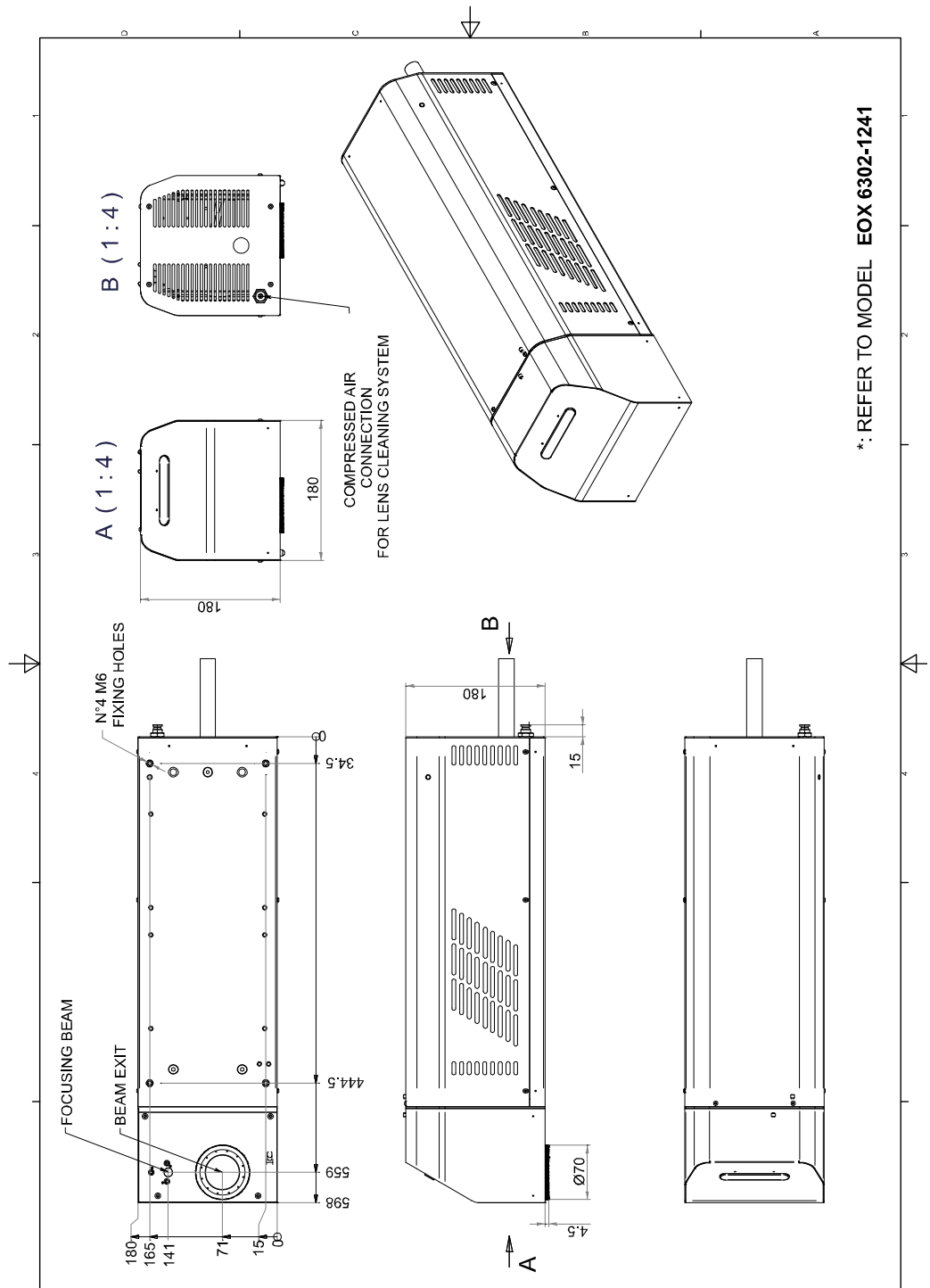

NOTE: Please refer to Datalogic website for detailed drawings.

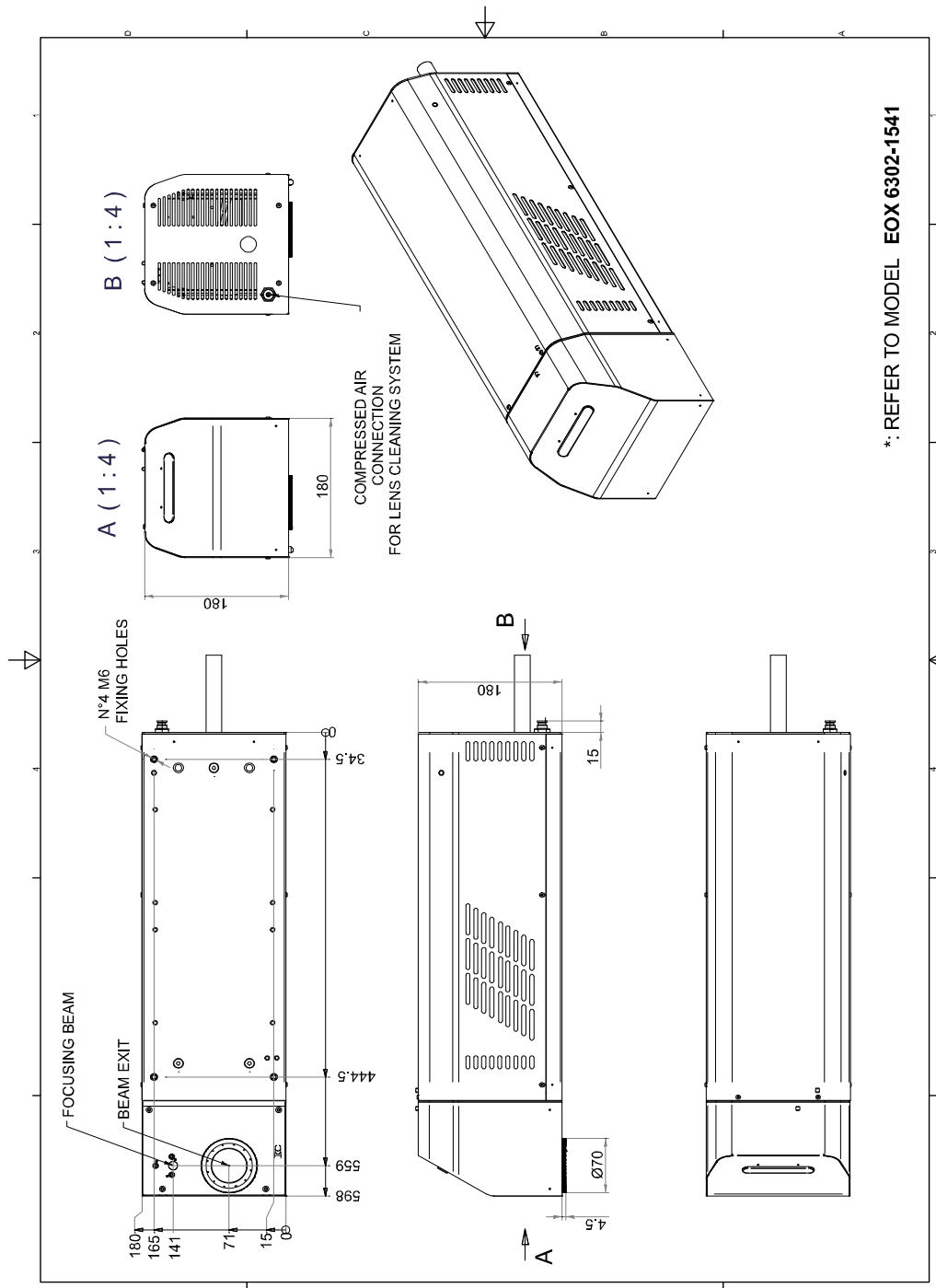

*: REFER TO MODEL EOX 6302-1541



NOTE: Please refer to Datalogic website for detailed drawings.

© 2021-2022 Datalogic S.p.A. and /or its affiliates • All rights reserved • Without limiting the rights under copyright, no part of this documentation may be reproduced, stored in or introduced into a retrieval system, or transmitted in any form or by any means, or for any purpose, without the express written permission of Datalogic S.p.A. and/or its affiliates • Datalogic and the Datalogic logo are registered trademarks of Datalogic S.p.A. in many countries, including the U.S. and the E.U.

 **DATALOGIC**
www.datalogic.com

Datalogic S.r.l.

Via S. Vitalino, 13 | 40012 Calderara di Reno | Bologna - Italy
Tel. +39 051 3147011 | Fax +39 051 3147205



801000120

(Rev A)

December 2022